

User Manual

9d24 MkII Cordless Handset

Contents

1 Introduction	1
1.1 Abbreviations and Glossary	1
1.2 System 9d	1
1.3 Versions	1
2 Safety Instructions	2
2.1 ATEX/IECEX Safety Instructions	3
2.2 Regulatory Compliance Statements (EU/EFTA only)	4
2.3 Environmental Requirements	4
3 Descriptions	5
3.1 The 9d24 MkII Cordless Handset	5
3.2 Battery	6
3.3 ATEX/IECEX-approved battery	7
3.4 Chargers	7
3.4.1 Desktop Charger	7
3.4.2 Charging Rack	8
3.5 Icons and Text in the Display	8
3.6 Keys and Buttons	11
3.6.1 Navigation Key	11
3.6.2 Menu key	11
3.6.3 Call Key	11
3.6.4 Soft keys	11
3.6.5 Hot keys	11
3.6.6 Volume Button	12
3.6.7 Mute Button	12
3.6.8 Alarm Button	12
3.6.9 Alpha Numeric Keys	12
3.7 Accessories	13
3.7.1 Belt Clip, Swivel-type	13
3.7.2 Leather Casing	13
3.7.3 Headset	13
3.7.4 Safety String	13
4 Basic Operation	14
4.1 Call List	14
4.2 Make a Call	14
4.3 Answer a Call	15
4.4 End a Call	15
4.5 Decline an incoming call	16
4.6 Transfer a Call	16

4.7 Turn Off Alert Signals at an incoming Call	16
4.8 Turn the Mute Mode during a Call Off/On	16
4.9 Loudspeaking Function	16
4.10 Increase/Decrease the Speaker Volume during a Call	16
4.11 Turn Audible Signals On/Off	16
4.12 Lock/Unlock the Keypad	17
4.13 Lock/Unlock the Handset	17
4.14 Switch the Handset On	17
4.15 Call menu	17
4.15.1 Start a New Call during Conversation	17
4.15.2 Transfer call	18
4.15.3 "Blind" transfer	18
4.15.4 Switch between existing calls	18
4.15.5 Conference call	18
4.15.6 Call back	18
4.15.7 General purpose options	18
4.15.8 Option shortcut	19
5 Messaging.....	19
5.1 Message List	19
5.2 Receive a Text Message	19
5.3 Message queuing and message priority	19
5.4 Prioritisation between Call Information and Messages	21
5.5 Restriction when displaying a message.	22
5.6 Receive a Text Message during a Call	22
5.7 Close message	22
5.8 Read a Stored Text Message	22
5.9 Delete a Stored Text Message	22
5.10 Receive a Message with Request for Answer	22
5.11 SMS (Short Message Service)	23
5.11.1 Send an SMS	23
5.11.2 Send an SMS to a predefined Destination Address	23
5.11.3 Display and Scroll between SMS Messages	23
5.12 Interactive Messaging	23
5.12.1 IM initiated Push-To-Talk (PTT)	24
5.13 Mobile Data	24
5.13.1 Send Mobile Data	24
5.13.2 Send Mobile Data with a Prefix	24
5.14 Conference Call	24
5.15 Call Setup Function	25
5.15.1 Push-to-talk (PTT) using Call Setup	26

5.15.2 Application Controlled Dialling of Digits	28
6 Alarm Operation	28
6.1 Push-button Alarm	28
6.2 Test Alarm	28
6.3 No-movement Alarm	28
6.4 Pull-cord Alarm	29
6.5 Man-down Alarm	30
6.6 Acoustic Localisation Signal	31
6.7 Delay Time before Warning for No-movement and Man-down Alarms	31
6.8 Alarm with Data	31
6.9 Automatic Call after an Alarm	31
6.9.1 Connection method Speech Monitoring	31
6.9.2 Connection method Loud	32
6.9.3 Connection method Ordinary	32
6.10 Alarm Management with Automatic Calls	32
7 Navigate the Menu	32
7.1 Enter/Exit the Menu Mode	33
8 Menu Tree	34
8.1 Messages Tab	34
8.2 Contacts Tab	34
8.3 Modes Tab	35
8.4 Services Tab	35
8.5 Settings Tab	36
8.6 Customizing the Menu Tree	37
9 Menu Operation	38
9.1 Messages	38
9.1.1 Message List	38
9.2 Contacts	39
9.2.1 Find an Entry in the Local Phonebook	39
9.2.2 View an Entry in the Local Phonebook	39
9.2.3 Add an Entry to the Local Phonebook	39
9.2.4 Delete an Entry in the Local Phonebook	40
9.2.5 Edit an Entry in the Local Phonebook	40
9.2.6 Find an Entry in the Central Phonebook	40
9.2.7 Save a Number from the Call List to the Local Phonebook	40
9.2.8 Delete a Number in the Call List	41
9.2.9 Delete All Numbers in the Call List	41
9.3 Modes	41
9.3.1 Change Modes	42
9.3.2 Change Mode Settings	42

9.3.3 Set the Mode to Absent On/Off	42
9.3.4 Choose the Modes Answering method	42
9.3.5 Switch the Handset Off	43
9.3.6 Customizing the Modes Menu	43
9.3.7 Change Mode Remotely	43
9.4 Services	43
9.4.1 Activate a Service	44
9.4.2 Create a new Service	44
9.4.3 Edit a Service	44
9.4.4 Delete a Service	44
9.5 Settings	45
9.5.1 Change the Volume	45
9.5.2 Change the Ring Signal	45
9.5.3 Key Beep On/Off	46
9.5.4 Vibrator On/Off	46
9.5.5 Deactivate/Activate No-movement alarm	46
9.5.6 Deactivate/Activate Man-down alarm	46
9.5.7 Deactivate/Activate Pull-cord alarm	46
9.5.8 Edit a Soft key	46
9.5.9 Edit a Hot key	47
9.5.10 Select Language	48
9.5.11 Change Text Size	48
9.5.12 Lock the Handset Manually	48
9.5.13 Change the Lock Code	48
9.5.14 Clock Settings	48
9.5.15 Turn On/Off Automatic Keypad Lock	49
9.5.16 Enable/Disable Quick Answer	49
9.5.17 Set New Messages to be Displayed Upside down	49
9.5.18 Set Owner ID	49
9.5.19 Select PBX System	50
9.6 Additional Information	50
10 Advanced Functions.....	50
10.1 System Handling	50
10.1.1 Register a New PBX System	50
10.2 Adjustment of Audio Parameters	51
10.3 DECT Location Feature	51
10.3.1 Location Test	52
10.3.2 Location Request	52
10.4 Field Upgrade	52
10.4.1 Upgrade	52

10.5 Updating Software	55
10.5.1 Downloading Software	56
10.5.2 Copying Software	56
10.6 Changing SIM parameters	57
10.7 Push-To-Talk (PTT) via Hot Key	57
11 Maintenance.....	57
11.1 Charge the Battery	57
11.1.1 Charging Spare Batteries	58
11.2 Replace the Standard Battery	59
11.3 Replace the ATEX/IECEX Battery	60
11.4 Change the SIM Card	60
11.5 Change the Clip	60
11.6 Attach Pull-cord Protection Plug	61
12 Trouble Shooting.....	61
12.1 Error message	62
Document History	63
Appendix A: 9d24 MkII Functionality with a 9d23 SIM.....	64
Index	65

1 Introduction

This document describes the features and settings available for the 9d24 MkII Cordless Handset. All procedures in this document are according to default programmed versions, but additional functions and factory settings are also included as an attempt to cover all functionality.

Note that your system may not supply all functions described in this document. For more information about your system please contact the person (or department) responsible for the system in your organization, or contact your supplier.

1.1 Abbreviations and Glossary

CNIP Calling Name Identification Presentation

1.2 System 9d

The 9d24 MkII Cordless Handset is part of a system that integrates Messaging, Personal alarm and Voice on a DECT platform. Hereby a system with digital voice quality, unique messaging and alarm possibilities is created.

The System 9d consists of; a Radio Exchange, DECT base stations, software package for message handling, software for configuration of the Radio Exchange and cordless handsets. The System 9d integrates the On-site Paging- and Personal Security Systems.

1.3 Versions

The 9d24 MkII Cordless Handset is a robust, dust- and waterproof (IP64) handset designed for people working in tough environments. It is suitable for users dependent of being reachable and/or having a need for advanced mobile messaging functions.

There are five versions of the Cordless Handset, 9d24 MkII Talker, 9d24 MkII Messenger with messaging functions, 9d24 MkII Protector with additional alarm functions and two

intrinsically safe versions 9d24 MkII ATEX/IECEx-Messenger and 9d24 MkII ATEX/IECEx-Protector.

Functions	Talker	Messenger	Protector	ATEX/IECEx-Messenger	ATEX/IECEx-Protector
SIM card with local phonebook	Yes	Yes	Yes	Yes	Yes
Central phonebook	Yes	Yes	Yes	Yes	Yes
Vibrator	Yes	Yes	Yes	Yes	Yes
Microphone on/off during call	Yes	Yes	Yes	Yes	Yes
Headset connector	Yes	Yes	Yes	Yes	Yes
Messaging*	-	Yes	Yes	Yes	Yes
Acknowledge*	-	Yes	Yes	Yes	Yes
Interactive messaging*	-	Yes	Yes	Yes	Yes
SMS (Short Message Service)*	-	Yes	Yes	Yes	Yes
Data Send*	-	Yes	Yes	Yes	Yes
Data with prefix*	-	Yes	Yes	Yes	Yes
Personal alarm*	-	-	Yes	-	Yes
Alarm with Data*	-	-	Yes	-	Yes
Location, base stations*	-	-	Yes	-	Yes
Location, DECT locators*	-	-	Option	-	Yes
Man-down & No-movement alarm*	-	-	Option	-	-
Pull-cord alarm*	-	-	Option	-	-
Upgradable to Messenger	Yes	-	-	-	-
Upgradable to Protector	Yes	Yes	-	-	-

Accessories	Talker	Messenger	Protector	ATEX/IECEx-Messenger	ATEX/IECEx-Protector
Headset					
with microphone on boom	Yes	Yes	Yes	-	-
with microphone on cable	Yes	Yes	Yes	-	-
with hearing protection	Yes	Yes	Yes	-	-
adapter for standard Peltor headset	Yes	Yes	Yes	Yes	Yes
EX-approved adapter for Peltor headset	-	-	-	Yes	Yes
Desktop charger	Yes	Yes	Yes	Yes	Yes
Charging Rack CR24	Yes	Yes	Yes	Yes	Yes
Belt Clip					
hinge-type	Yes	Yes	Yes	Yes	Yes
swivel-type	Yes	Yes	Yes	Yes	Yes
Leather case	Yes	Yes	Yes	-	-
Security string	Yes	Yes	Yes	Yes	Yes
Spare battery	Yes	Yes	Yes	Yes	Yes

* System dependent feature

2 Safety Instructions

For safe and efficient operation of the handset, observe the guidelines given in this manual and all necessary safety precautions when using the handset. Follow the operating instructions and adhere to all warnings and safety precautions located on the product, the Quick Reference Guide and this User Manual.

This product shall only be used with the following batteries:

- Art.No.: 660087 Battery
- Art.No.: 660088 Battery Medic
- Art.No.: 660121 Battery ATEX/IECEx-version

Single chargers shall only be connected with power adapters supplied by the manufacturer.

Available power adapters:

- Art.No.: FW7650/05 Power supply unit AC/5V DC/1A

Warranty notification

Do not disassemble the handset. Disassembling the handset voids the warranty. The 9d24 MkII handset consists of no consumer serviceable components. Service should be performed by Authorized Service centre only.

2.1 ATEX/IECEX Safety Instructions

Intrinsically safe classification

 II 2G, II 3D	CE 0518
EX ib IIC T4	IECEX SIR 06.0093X
EX ibD 22 IP64 T50°C	SIRA 05ATEX2310

Charge the battery

When charging an intrinsically safe ATEX/IECEX transceiver in a PCR Charging Rack, the rack must be version 2A or higher.

In combination with ATEX/IECEX-version, use approved battery types only. The battery must be marked with RAID2 on the label.

Charging parameters: $U_m = 5,25 \text{ V}$, $I_m = 1,25 \text{ A}$

IMPORTANT: Battery charging or replacement is NOT permitted in a hazardous area.

For approved battery types, see EC Type examination Certificate SIRA 05ATEX2310 and IECEX Scheme Certificate of Conformity IECEX SIR 06.0093X and following supplements.

The document above and the EC Declaration of Conformity can be found at:

http://www.ascom.com/ws/products_ws.htm and <http://www.iecex.com>

Remove the battery

The battery is fastened by a screw that requires a special tool, Battery Pack Opener for ATEX. See also [11.3 Replace the ATEX/IECEX Battery](#) on page 60.

IMPORTANT: Removing the battery is NOT permitted in a hazardous area.

Attention

- The product is housed in an enclosure that meets IP64. However, the ATEX/IECEX classified handset is not intended to be immersed in dust or water.
- In the case of damage suspect, do not use the ATEX/IECEX classified handset in a hazardous area.
- Make sure that the product marking corresponds to the site requirements.
- Before installation consult the product documentation.

- National safety rules and regulations have to be observed.
- Do not use accessories to the product without ensuring that they are suitable for use in a hazardous area.
- Modification of the product is not permitted.
- Product repair has to be done at authorised repair shops only.

2.2 Regulatory Compliance Statements (EU/EFTA only)

This equipment is intended to be used in the whole EU & EFTA.

This equipment is in compliance with the essential requirements and other relevant provisions of R&TTE Directive 1999/51/EC. The Declaration of Conformity may be consulted at:

http://www.ascom.com/ws/products_ws.htm

The handset is marked with the label 

2.3 Environmental Requirements

Cordless Handset

- Only use the handset in temperatures between 0 °C to +40 °C.
- Avoid exposing in direct sunlight or close to other heat sources.
- Protect your handset from aggressive liquids and vapours.
- Keep the handset away from strong electromagnetic fields.

Battery

- Do not immerse the battery into **liquid**, **dust** or throw into fire.
- Use the Desktop Charger or the wall mounted Charging Rack for charging. Charge the battery for at least one hour the first time you use the battery. Note that the wall mounted charger with a battery pack adapter has to be used if the battery alone is to be charged.

3 Descriptions



Figure 1. Description of the handset.

3.1 The 9d24 MkII Cordless Handset

Case

The case is made of durable PC/ABS plastic and is water, dust and soil protected. The joint between the front and rear parts of the handset casing has a gasket made of elastic plastic (thermoplastic polyester elastomer, TPE), as does the battery. Even the headset connector has a tightening TPE gasket, preventing dust and water from getting inside also when the headset is not connected.

The 9d24 MkII Handset has the enclosure protection IP64 which means that dust (talcum powder) and splashing water can not penetrate the handset. It also fulfils IEC 60068-2-32 procedure 1, witch means that it is tested to stand for 2 falls on each side, (totally 12 falls) from the height of one meter onto painted concrete floor.

The alpha and numeric characters printed on the exterior of the 9d24 MkII Handset have been tested and found resistant to chipping, fading or wearing off when the handset is treated with common cleaners and disinfectants or perspiration. The following chemicals have shown no harmful effect:

3% Hydrochloric Acid
M-alcohol (70% Methylated Ethanol)
60% Chlorhexidin 0.5mg/ml

Antenna

The antennas are integrated inside the handset.

Display

The display is an illuminated 128 x 64 pixels LCD, covered by anti-reflex treated plastic glass for maximum readability.

It is possible to manually adjust the display contrast.

Keypad

The keypad is illuminated, which makes it possible to operate the handset in dark environments. While not in use the keypad should be locked to prevent pressing a key accidentally.

Clip, Hinge-type

The clip on the back of the handset helps you fasten the handset to a belt or similar.

It is also possible to change the clip to a swivel-type or if no clip is needed, to replace it with a covering plate.

SIM Card

The SIM card contains all personal settings such as phonebook, identity, alert signal and your defined functions of the Soft keys and Hot keys. This means that all personal settings will be retained if the SIM card is moved to another handset.

3.2 Battery

The battery is a rechargeable Li-Ion battery placed on the back of the handset.

There are two similar handsets, 9d24 and 9d24 MkII. The battery for 9d24 does not fit the 9d24 MkII and vice versa. If the wrong battery type is used, the handset will not work. The handset or the battery will not be harmed in any way.

To make sure the correct battery is used for 9d24 MkII, check one or more of the following:

- The article number should be 660087, 660088 (Medic) or 660121 (ATEX/IECEx-version)
- The battery type should be Lithium Ion Battery
- The back plate of the battery should be black

- The label should be marked with "Only to be used in RAID2-XXXXX"

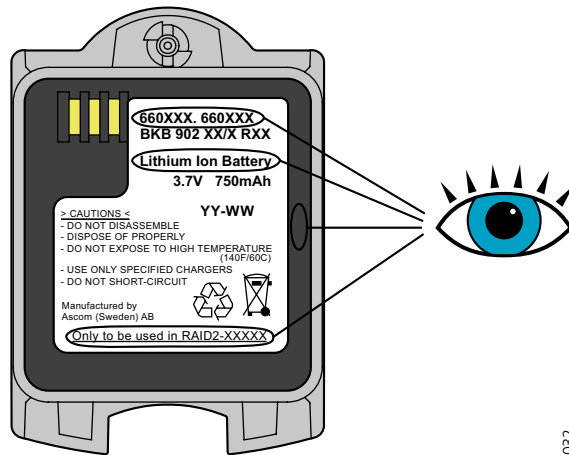

Figure 2. Make sure the correct battery is used.

3.3 ATEX/IECEx-approved battery

Note: The 9d24 MkII ATEX/IECEx-Messenger and 9d24 MkII ATEX/IECEx-Protector shall be used with special ATEX/IECEx-approved batteries (Art.No. 660121).

The ATEX/IECEx-approved battery should be marked with the text: "Battery charging or replacement is NOT permitted in hazardous area." The ATEX/IECEx-approved battery can only be opened with a special Battery Pack Opener. See [11.1 Charge the Battery](#) on page 57.

3.4 Chargers

3.4.1 Desktop Charger



The Desktop Charger is used for charging your handset, for example at your desk. The tilted design facilitates the use of handsfree operation, e.g. in loudspeaking mode. The charger is delivered with a plug-in power supply and is connected into a wall socket.

Desktop Charger shall only be connected to power adapters supplied by the manufacture.

Available power adapters (Suppliers Designation) are:
P/N FW7650/05 Power Supply unit AC/5V DC/1A.

Note: When charging an ATEX/IECEx-version the Desktop Charger must be marked with DC2.

3.4.2 Charging Rack

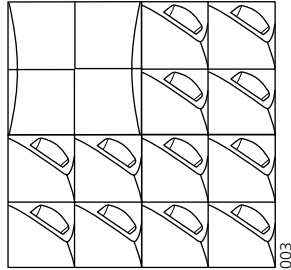

Figure 3. Wall mounted Charging Rack with power supply

The Charging Rack is used for charging your handset and/or spare batteries. When charging spare batteries an adapter is needed. The wall mounted Charging Rack and its power supply are a modular system which enables a number of installation configurations. Each power supply can support several charging racks with four positions for handsets and/or batteries in each rack (see *Data Sheet Charging Rack TD 92382GB*). Handsets with pull-cord alarm can be charged in the Charging Rack without removing the pull-cord catch.

As the handset cannot distinguish between a Desktop Charger and Charging Rack, it is recommended that the alert signal is silenced when placed in a rack. It can be set in the "In charger" mode, see [9.3.2 Change Mode Settings](#) on page 42. There is also a SIM parameter that can be set in the SIM Card Programmer by your system administrator.

Note: When charging an ATEX/IECEx-version the Charging Rack must be marked with CR2.

3.5 Icons and Text in the Display

The icons and text in the display indicate functions and settings to which you have access. The display normally shows the owner ID and the system ID, for example "System A". This indicates that the handset is in contact with System A. The owner ID is manually set by the user.

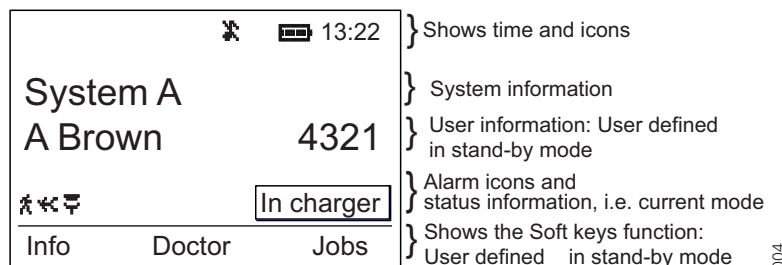

Figure 4. Example of a display configuration in stand-by mode.

In stand-by mode the upper row is used for icons and the clock. Three rows are used for information. First row for system information and second row for user information. The user information in stand-by mode can be set by the user. The third information row is used for showing the alarm icons and status of the handset. Examples of status information are; muted, in charger etc. When there is no status to show the row is empty.

The bottom row (under the line) is the Soft key field. In stand-by mode it shows the user defined names of the three Soft keys beneath the display. In menu mode where the Soft keys are used for different choices, it gives you the function of each Soft key. Examples of functions are; Back, Option, Save etc.



"Hook off" icon indicates that your handset is off hook.



"Audio signal off" icon is shown when all alert signals, including ring signal, message tone, key beep etc. are turned off. High priority messages will however override this setting.



"Battery" icon is always shown in the display in stand-by mode. When the level is low it is time to charge the battery.



"Loudspeaking" icon is shown when the loudspeaker is activated and the handset is in loudspeaking operation.



The "New voice mail" icon appears when a new voice mail exists. The symbol will remain until all voice mails has been listened to and/or removed.



"New message" icon appears when a new message is received. The number on the right side of the icon shows the total number of unread messages. The symbol will remain until the message is marked as read.



"New voice mail" icon and "New message" icon flashing appears when there are both Voice mail and new messages.



"Unread message" icon appears when reading one message and there are unread messages in the message list.



"Not answered call" icon is added to not answered calls in the call list. The number on the right side of the icon shows the total number of missed calls.



"Key" icon indicates when your keypad is locked.



The "Padlock" icon indicates that the handset has been locked and has to be unlocked with a code before it can be used.



"Headset" icon indicates that a headset is connected to the handset.



"No-movement alarm on" icon indicates that the no-movement alarm is activated.



"Man-down alarm on" icon indicates that the man-down alarm is activated.



"Pull-cord alarm on" icon indicates that the pull-cord alarm is activated.

ABC

"ABC" indicates that you can type upper case letters and numbers in text input mode.

abc

"abc" indicates that you can type lower case letters and numbers in text input mode.

123

"123" indicates that you can type numbers in text input mode.



"Incoming call" icon is added in front of incoming calls in the call list.



"Outgoing call" icon is added in front of outgoing calls in the call list.



"Unread message" icon is added in front of not read messages in the message list.



"Read message" icon is added in front of read messages in the message list.



"Interactive message" icon is added in front of not read interactive messages in the message list.



"Read interactive message" icon is added in front of read interactive messages in the message list.



"Add contact" icon appears on a Soft key when a phone number is marked in the call list. It indicates that it is possible to add the phone number to the local phonebook.



The "Contacts" icon is viewed when it is possible to get a phone number from the local phonebook, for example to add it to a function.

Menu Tabs:

All tabs are displayed when you press the Menu button



Under the tab "Messages" in the menu mode, you can find the message list. See [9.1 Messages](#) on page 38.



Under the tab "Contacts" in the menu mode, you can find the local and central phonebooks and the call list. See [9.2 Contacts](#) on page 39.



Under the tab "Modes" in the menu mode, you can select between modes and change and edit Modes. See [9.3 Modes](#) on page 41.











Under the tab "Services" in the menu mode, you can select, add, delete, or change a service function. See [9.4 Services](#) on page 43.



Under the tab "Settings" in the menu mode, you do your handset settings. See [9.5 Settings](#) on page 45.

3.6 Keys and Buttons

3.6.1 Navigation Key

The Navigation key  controls the movement of the cursor in the display. In stand-by mode, the Navigation key  is used for entering the Call list, the Navigation key  for entering the Message list and pressing Navigation key  will show the current date in the display window. When navigating in the menu the key is used for moving up , down , back , or next .

3.6.2 Menu key

The Menu key  is used for entering the Menu.

3.6.3 Call Key

The Call key  is used for connecting and disconnecting calls.

3.6.4 Soft keys

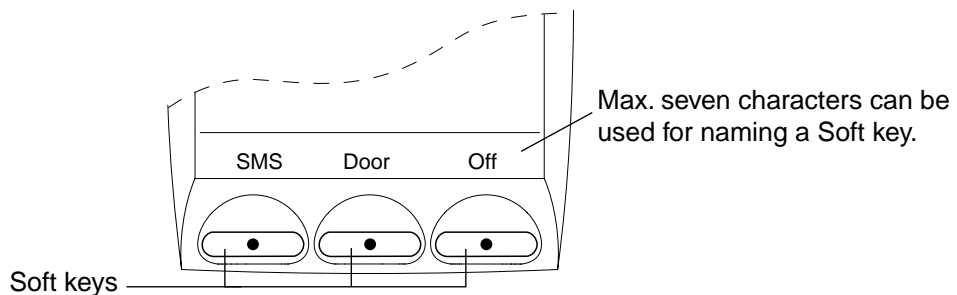

Figure 5. Soft keys

The three Soft keys are located just beneath the display and the function of each Soft key is indicated by text in the display just above the keys.

In stand-by mode the Soft keys can be used for specific functions defined by the user of the handset. The function can be to dial a specific telephone number, sending mobile data, a shortcut to the menu, or sending SMS.

When navigating in menu mode the Soft keys are used for different choices in the menu.

3.6.5 Hot keys

Any key "0" - "9" can be set to a Hot key. Any Hot key can be programmed to give access to frequently used functions such as dialing a specific telephone number, sending mobile data, a shortcut to the menu, or sending SMS. Note that the possibility to define a Hot key can be locked by your system administrator.

3.6.6 Volume Button

The Volume button is used for increasing/decreasing the loudspeaker volume.

Note: Depending on setting, answering an incoming call with the "volume up" can be disabled.

3.6.7 Mute Button

The Mute button is used for silencing the audible signals in stand-by mode, silencing the ring signal at an incoming call and also to turn off/on the microphone during a call.

Note: Depending on setting, the mute function during ringing can be enabled/disabled.

3.6.8 Alarm Button

The red Alarm button is used for sending alarms and for testing the alarm function (test alarm).

3.6.9 Alpha Numeric Keys

In some applications you have the possibility to write letters as well as numbers, which is indicated by the "ABC" icon. Pressing the numerical keys will now give you access to the alphabet plus some special characters according to the picture beneath.

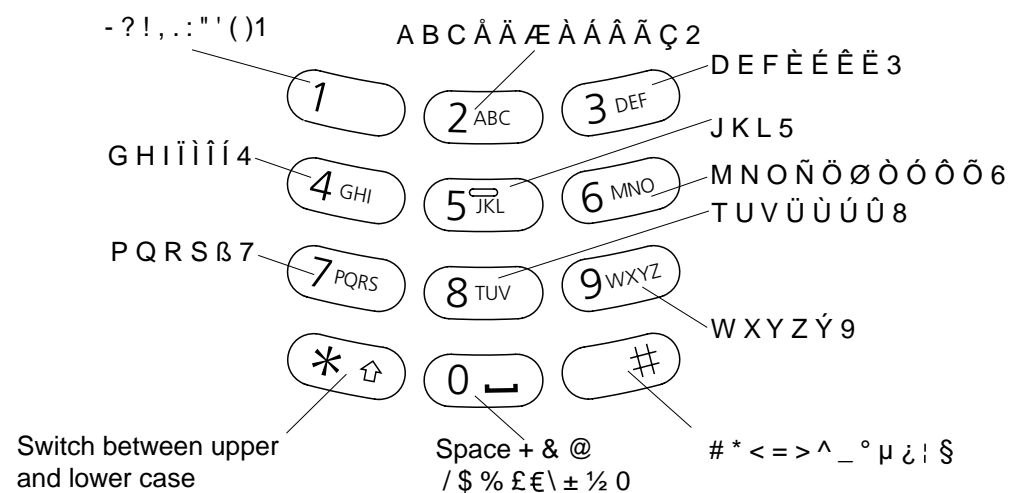

Figure 6. Alpha Numeric Keys

In Stand-by Mode

In stand-by mode short presses on the keys enter the digits and the characters * and #. A long press on a key "0" - "9" activates the programmed Hot key function.

In Text input Mode

In text input mode a press on a key displays the first available character on that specific key. Continue pressing the key to view the following characters. The marked character is selected after a time out or when another key is pressed. Press the *-key to switch

between upper case and lower case. A long press in text input mode will give the number.

3.7 Accessories

3.7.1 Belt Clip, Swivel-type

The ordinary belt clip can be replaced with a special swivel-type belt clip adapted to firmly place your handset onto your belt.

3.7.2 Leather Casing

The leather casing is especially designed for the handset. The casing comes with a swivel-type belt clip and the handset is fully operational while placed in the casing. The leather casing can easily be modified for use with handsets equipped with pull-cord alarm.

Note: The Leather Casing is not approved for use in ATEX/IECEx-classified area.

3.7.3 Headset

A headset is recommended if you frequently use the phone and/or want to have both hands free. The handset has a special headset connector that is waterproof. The headset comes in three versions; with microphone integrated in the cable, with microphone on a boom and with hearing protection (Peltor). An adapter, that makes it possible to connect other standard types of Peltor headsets, is also available.

In order to achieve optimal audio quality with the different headset types it is recommended that the SIM parameter called "Headset type" is altered to match the headset type being used. The default setting for this parameter is microphone on a boom i.e. the audio is optimized for using a headset with microphone on a boom.

ATEX/IECEx classified Headset

The ATEX/IECEx Headset with hearing protection from Peltor must be connected to an ATEX/IECEx Headset Adapter for Peltor Headset.

IMPORTANT: Headset used in combination with an ATEX/IECEx classified 9d24 MkII ATEX/IECEx-version must have the same ATEX/IECEx classification as the handset to fulfil the ATEX/IECEx directive.
ATEX/IECEx classified headsets must be ordered directly from Peltor®, see the Peltor homepage (www.peltor.se) for more information.

3.7.4 Safety String

The safety string is 800 mm long. Fasten one end to the hinge-type belt clip and the other end to, for example, your pocket.



4 Basic Operation

4.1 Call List

The twenty last received/dialled telephone numbers are stored in a call list. Open the call list by pressing the Navigation key , or from the menu, see 9.2 *Contacts* on page 39. If the clock and date function is set, you can on the same day the call was received/dialled, see the time for the call. The time stamp is changed to a date stamp the following day.

4.2 Make a Call

Pre-dial

Enter the number and press the Call key  to get the line. The number is shown on the display while dialling. If needed, you can press the Soft key "C" to erase and edit the number. By using Navigation key  or  it is possible to step and add/delete a digit in the middle of a number.

It is possible to turn on/off the tone sender in a predialled number by making a long press on the *-key. Tone sender on will be indicated with a "T" in the number and off with "-". If a pause is required in the number, it is added by making a long press on the #-key. The pause is indicated with a "P" in the number.



Post-dial

Press the Call key  to get the line and enter the number. The number will not be added to the call list when post-dial is used.

Dial using a pre-programmed Hot key or Soft key



A Hot key or Soft key can be programmed with a telephone number. Press the pre-programmed Hot key or Soft key (or headset button if parameter is set). The call will automatically be connected.

Dial a number from the Call list







Enter the call list with Navigation key , or from the menu. Select a number and press the Call key .



The number in the call list can be edited before the call is started. Press "Edit", make the changes and press the Call key .

Dial a number from a Message

You can dial a number included in a received message by pressing the Call key . The first number in the message is dialled. If the message is stored in the message list, open the list by pressing Navigation key . Select the message and press the Call key .

Dial a number from the Local Phonebook

- 1 Press the Menu key  (the last used tab is opened).
- 2 Press Navigation key  or  and select the tab Contacts .
- 3 Press Navigation key  and step to "Local Phonebook".
- 4 Press Navigation key ; a name list is shown.

- 5 Step in the list by using Navigation key  or . The selected entry is highlighted. Press the Call key .

Start a New Call during Conversation

Press the right Soft key "R" during a call. Dial the number you want. Wait for answer. Switch between the connected calls by using the Soft key "R".

Special Call Functionality

When using a headset: Depending on set parameter (*Headset_function* parameter in the SIM card Programmer software) the off-hook functionality may differ when using the headset answering button.

By default the headset button can be used to answer incoming calls only (parameter set to 0). If the parameter is set to 1, the headset button works as off-hook like using the Call key . It is then possible to both answer incoming calls and to get the line. If the parameter is set 10-19, the headset button triggers specified hot-key 0-9.

The headset button overrides the Auto key lock ("Locked keypad" in the display) and Phone Lock when this setting is not set to 0.

Depending on settings, it is possible to let the handset automatically dial a pre-programmed phone number, for example the reception, when the handset is inserted or removed from the charger. If the handset is put in a charger during an ongoing call, this function is disabled. This is done by connecting a hot key to the "in charger" or "out of charger" event.

Note: Using the *Headset_function* parameter reduces the stand-by time.

4.3 Answer a Call

The flashing LED, accompanied by a ring signal and/or a vibrating handset, gives you notice of a call. Ring signal and vibrator can be disabled. If supported by your PBX, the calling party's phone number and/or name is shown. The name will also be shown if the calling party's phone number is stored in the Local phonebook. Press the Call key  to answer the call. When a headset is connected to the handset, the answering button on the headset can be used to answer the call.

You can also set other answering methods in the modes settings. The answering methods are Ordinary, Auto, Loud and Auto loud. See [9.3 Modes](#) on page 41 for more information. In the settings menu , you can enable Quick Answer, see [9.5.16 Enable/Disable Quick Answer](#) on page 49.

Note: Depending on settings, it is possible for the user to answer a call with the "Volume up" button. To avoid accidental press on the "Volume up" button or "Mute" button, any or both of these settings can be disabled.

4.4 End a Call

Press the Call key . When a headset is connected to the handset, the button on the headset can be used to end the call. All connected calls are ended. The total call time is shown in the display.

4.5 Decline an incoming call

Press the Soft key "Decline" to decline an incoming call.

4.6 Transfer a Call

Press the Soft key "R" during a call. Dial the number to the person you want to transfer the call to. Wait for an answer and press the Call key .

In case the person you are trying to transfer the call to is not answering, you can take back the call by pressing the Soft key "R" again.

This is the default setting. To make it easier for the user see [4.15 Call menu](#) on page 17.

4.7 Turn Off Alert Signals at an incoming Call

Press the Mute button before answering the call. All alert signals, including the vibrator, will silence for that specific call.

4.8 Turn the Mute Mode during a Call Off/On

A press on the Mute button disconnects/connects the microphone. The text "Muted" is shown in the display when the microphone is off during a call.

4.9 Loudspeaking Function

How you activate the loudspeaking function is dependent of the choice of answering method. An incoming call can be connected with loudspeaking function active by pressing Volume button (up) or middle Soft key. During a call, a press on the middle Soft key activates the loudspeaking function. Press the middle Soft key again to turn it off.

You can also activate this function by selecting another answering method, see [9.3.4 Choose the Modes Answering method](#) on page 42. For the loudspeaking function you have three choices in the menu:

- Ordinary. The loudspeaking function is turned on when the middle Soft key is pressed
- Loud. A call is connected with the loudspeaking function turned on when the Call key  is pressed.
- Auto loud. An incoming call is automatically connected after 2 signals with the loudspeaking function turned on. Calls can be answered as usual before that.

4.10 Increase/Decrease the Speaker Volume during a Call

Press the upper part of the Volume button to increase the volume and press the lower part to decrease the volume.

4.11 Turn Audible Signals On/Off

In stand-by mode a long press on the Mute button changes between audible signals on/off and the icon appears/disappears. "Audio signal off" icon indicates a completely silenced handset. Only highest priority messages will override this silent mode.

4.12 Lock/Unlock the Keypad

Press the Menu key  and then the *-key to lock/unlock the keypad. The "Locked keypad" icon indicates a locked keypad. It is possible to lock the keypad during a call.

The keypad can also be locked automatically, see [9.5.15 Turn On/Off Automatic Keypad Lock](#) on page 49 for more information.

4.13 Lock/Unlock the Handset

You can protect your handset from being used by others by locking it automatically when placed in a charger or switched off. The handset can only be unlocked with a 1 to 4 digit code. When the handset is locked, it is still possible to send all types of alarms.

This function requires a SIM card parameter setting. The function can only be enabled/disabled in the SIM card, not from the handset. The code is set in the SIM card and can be changed from the handset, see [9.5.13 Change the Lock Code](#) on page 48 for more information.

The handset can also be locked manually, see [9.5.12 Lock the Handset Manually](#) on page 48 for more information.

4.14 Switch the Handset On

Press and hold the Call key  until "Switch on?" is displayed. Press "Yes" while the question is shown in the display window. The question is displayed for ten seconds.

How to switch the handset off is described in [9.3.5 Switch the Handset Off](#) on page 43.

4.15 Call menu

It is possible to program a Call menu via the SIM. The purpose of the Call menu is to simplify exchange specific commands during a call. In the SIM card programmer the different programmable options for the Call menu are described under the Settings\Call menu folder.

During a call the Call menu is found on the left Soft key, "Options".

Only the programmed options will be visible in the menu. They will appear in an order which can not be changed.

The following options are available in the Call menu (when programmed):

4.15.1 Start a New Call during Conversation

The purpose of this option is to allow users to place another call while placing the ongoing call on hold. If the "New call data" parameter in the SIM is programmed, the call menu will contain the option "New call".

- 1 Press the "Options" Soft key during the call
- 2 Mark "New call" and press "Select".
- 3 Dial the number and press the "Ok" Soft key.

When entering the number it is possible to press "C" Soft key to erase.

Instead of entering the number it is possible to press the  Soft key and choose a number from the local phonebook.

4.15.2 Transfer call

The purpose of this option is to allow users to transfer an established call to another established call. If the "Transfer call data" parameter in the SIM is programmed, the call menu will contain the option "Transfer".

- 1 Press the "Options" Soft key during the call
- 2 Mark "Transfer" and press "Select".

4.15.3 "Blind" transfer

The purpose of this option is to allow users to transfer an established call to a number to which no call has been established yet. The transferred party will then be calling the number specified by the user. If the parameters "New call data" and "Transfer call data" in the SIM are programmed, the call menu will contain the option "Transfer to new call".

- 1 Press "Options" during the call
- 2 Mark "Transfer to new call" and press "Select".
- 3 Dial the number the person you want to transfer the call to. Press "Ok" to transfer the call.

Instead of entering the number it is possible to press the  Soft key and choose a number from the local phonebook.

4.15.4 Switch between existing calls

The purpose of this option is to allow users to switch between established calls. If the "Switch call data" parameter in the SIM is programmed, the call menu will contain the option "Switch".

- 1 Press "Options" during the call
- 2 Mark "Switch" and press "Select".

4.15.5 Conference call

The purpose of this option is to allow users to establish a conference call with all established calls. If the "Conference call data" parameter in the SIM is programmed, the call menu will contain the option "Conference".

- 1 Press "Options" during the call
- 2 Mark "Conference" and press "Select".

4.15.6 Call back

The purpose of this option is to allow users access to call back functionality. If the "Call back data" parameter in the SIM is programmed, the Call menu will contain the option "Call Back".

- 1 Press "Options" during the call
- 2 Mark "Call back" and press "Select".

4.15.7 General purpose options

The purpose of these options is to allow users to configure the Call menu to provide access to other exchange functionalities than those described above.

It is possible to program five "general purpose" options. Each such option consists of "name" and "data". If both name and data (for the same option) are programmed in the SIM, the option will appear in the Call menu, the name of the option being displayed.

4.15.8 Option shortcut

It is possible to create a shortcut to one of the options in the Call menu. If the SIM parameters "General SoftKey name" and "General SoftKey data" are programmed and the data of the option indicated by "General SoftKey data" has a value, then the shortcut name will appear as the right Soft key in the call screens. When selecting this shortcut, the option indicated by the "General SoftKey data" will be executed according to the descriptions above.

This will replace the "R" Soft key while in a call.

5 Messaging

Note: 9d24 MkII Messenger and 9d24 MkII Protector only.

5.1 Message List

Up to twenty messages can be stored in the message list (including the message queue), if the total number of characters does not exceed 20 000 including Interactive Messaging (IM) data. When the total number of characters exceed 20 000, the oldest stored message is deleted from the list. Use the Navigation key  to enter the message list. It is also possible to enter the message list via the menu, see [5.8 Read a Stored Text Message](#) on page 22.

5.2 Receive a Text Message

The flashing LED, accompanied by a message tone and/or a vibrating handset, gives you notice of a message. The message tone can be silenced by a press on the Mute button. The message tone will break through silent mode if the message is urgent. The message is shown on the display. The size of the text can be changed, see [9.5.11 Change Text Size](#) on page 48. The text can also be displayed upside down, see [9.5.17 Set New Messages to be Displayed Upside down](#) on page 49.

By pressing any key (not alarm, mute and volume buttons) the received message is marked as read.

Delete the received message

Press the Soft key "Delete" when the message is viewed on the display or marked in the Message list. The question "Delete message?" is shown; press "Yes".

5.3 Message queuing and message priority

This function is default set to On, i.e. SIM parameter "Time to read" set to 20 seconds. To turn the function Off set the "Time to read" parameter to 0.

If several messages are received during a short period of time it is possible to set, with the SIM parameter "Time to read", at which rate the messages will be shown on the display.

"Time to read" is the minimum time each message will be shown on the display without being interrupted by another message, except if the new message is of higher priority.

Messages that are not shown yet are placed in a queue. The priority and time of reception determine the position in the queue.

There are 9 levels of the priority. 1 is highest priority and 9 is lowest priority. If several of the messages have the same priority the message that was received first is shown first.

The total number of messages in the queue and the message list can not exceed the total number of characters stored, see [5.1 Message List](#) above.

If a new message with a higher priority is received while another message is read the new message will replace the old message in the display. The old message will be placed in the queue.

If a new message with equal or lower priority is received while another message is read the new message will be placed in the queue.

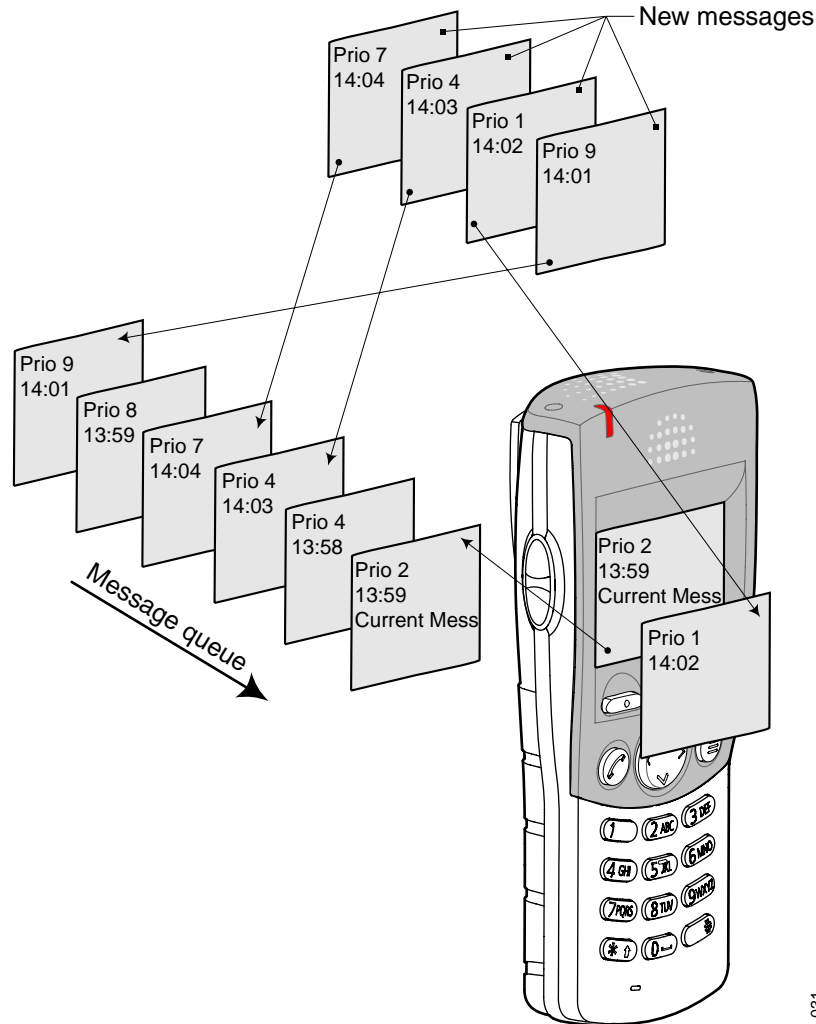

Figure 7. Figure of how the queue and priority works.

Messages in the queue will be shown automatically when the "Time to read" has passed for the previous displayed message or the message is closed or deleted. Queued messages will always be shown instead of the idle-screen until the queue is empty.

Unread message indication while displaying a message

A envelope icon, see [3.5 Icons and Text in the Display](#) on page 8, will be flashing in the display if there are unread messages in the queue.

5.4 Prioritisation between Call Information and Messages

It is possible to control the prioritisation between Call Information (for example CNIP) and Messages. The control is managed by two SIM parameters "Call priority" and "Disable call information" found in the setting folder in the SIM Card Programmer.

5.5 Restriction when displaying a message.

It is possible to prevent the Menu from being opened when displaying a message. This is set by the SIM parameter "Restrict menu".

5.6 Receive a Text Message during a Call

During a connected call a new message is indicated by a beep. The characteristics of the beep is the same as the message tone.

Depending on parameter settings in the handset, an urgent message can be permitted to disconnect the call.

5.7 Close message

A message can always be closed by pressing the Navigation key <.

5.8 Read a Stored Text Message

- 1 Open the message list by pressing Navigation key ^, or enter the menu by pressing the Menu key (☰) and select the Message tab .
- 2 Navigate in the list with Navigation key ^ or v. The selected message is highlighted.
- 3 Press Navigation key > to read the message.

If the clock and date function is set, you can on the same day the message was received, see the time for the message. The time stamp is changed to a date stamp the following day.

5.9 Delete a Stored Text Message

- 1 Open the message list by pressing Navigation key ^, or enter the menu by pressing the Menu key (☰) and select the Message tab .
- 2 Navigate in the list with Navigation key ^ or v. The selected message is highlighted.
- 3 Press "Delete". The question "Delete message?" is shown; press "Yes".

5.10 Receive a Message with Request for Answer

A message with request for answer is indicated with a different message tone. It is viewed the same way as an ordinary message, see [5.2 Receive a Text Message](#) on page 19. The text "Acknowledge" is added to the message. Use the Soft keys to do a positive or negative acknowledgement.

Accept/Reject the message

Press the Soft key "Accept" or "Reject". In the message list an acknowledged message is indicated by the text "Accepted" or "Rejected".

Note: The option "Delete" is not available for a message with request for answer. An unacknowledged message can only be deleted from the message list.

5.11 SMS (Short Message Service)

Note: 9d24 Messenger and 9d24 Protector only.



SMS messages can be sent from one handset to another. A Soft/Hot key and a Service can be programmed with a SMS function.

An incoming SMS is immediately displayed and the number of the sending handset is shown on a separate row.

Sending SMS is a system dependent function.

5.11.1 Send an SMS

There are three ways to send an SMS:

- Select the Messages tab  and press the Navigation key  to enter "Send SMS".
- A programmed Soft/Hot key, see [9.5.8 Edit a Soft key](#) on page 46.
- Use Service, see [9.4 Services](#) on page 43.





Enter the destination address or fetch it from the Local phonebook by pressing the Soft key with the "Contacts" icon ; press "Ok". It is possible to program the Soft/Hot key and the Service with a predefined destination address. If the address is not entered, an error message will be displayed. Enter text and press "Send". "Sending" will be displayed as a confirmation of the transfer.

5.11.2 Send an SMS to a predefined Destination Address

Press and hold the pre-defined Soft-/Hot key, or select the Service. Enter text and press "Send". "Sending" will be displayed as a confirmation of the transfer.

5.11.3 Display and Scroll between SMS Messages

SMS messages are saved along with other messages in the message list.

- 1 Press the Navigation key  to enter the message list. Press the Navigation key  or  to step in the list. Only one row per message is displayed.
- 2 Press Navigation key  to see the whole message. The time and date the SMS was received and the number of the sending handset is also shown.

5.12 Interactive Messaging

Note: 9d24 MkII Messenger and 9d24 MkII Protector incl. ATEX/IECEx-versions only.

Interactive Messaging (IM) is a function that extends basic messaging. It makes it possible for a user of a handset to access information from a client application in the system.

An example can be a customized application that can be accessed from the handset. A list of actions can be included in the message sent from the application to the handset. The actions will be shown as Soft keys, if there are three or less actions and the action name is seven or less characters.

Mobile data from the handset can initiate the application to send the interactive message, see [5.13 Mobile Data](#) on page 24. The user can then select one action from the list. The action can be sending a message back to the application and/or dialling a specific number etc.

An IM is indicated and viewed the same way as an ordinary message, see [5.2 Receive a Text Message](#) on page 19, but the "Interactive message" icon is added in front of the message. It is saved along with other messages in the message list.

Open an Interactive Message the same way as an ordinary message. If the IM gives you several options, mark the one you want and press "Select". If the selected option requests input, enter the information needed and press "Ok". A press on the middle Soft key will change to digit or text input mode depending on if it is digit or text format in the message.

Interactive Messaging is a system dependent function.

Note: If a cordless handset receives an IM update when the original message already has been deleted, the handset automatically sends a negative acknowledge (NAK) to the system, if requested.

5.12.1 IM initiated Push-To-Talk (PTT)

Depending on application, it is possible to send an Interactive Message (IM) and let the called party answer in PTT mode. Then, the voice is only transmitted when the called party holds down the mute button. When releasing the mute button, the voice transmission stops and it is only possible to listen in.

This function is easily noticed in the display window of the handset: "Muted" is shown when the "Mute button" is released, and disappears when the "Mute button" is pressed (inverted mute function).

See also [5.15.1 Push-to-talk \(PTT\) using Call Setup](#) on page 26 and [10.7 Push-To-Talk \(PTT\) via Hot Key](#) on page 57.

5.13 Mobile Data

Note: 9d24 MkII Messenger and 9d24 MkII Protector only.

5.13.1 Send Mobile Data

It is possible to send user entered data from the handset by pressing a pre-programmed Hot key or Soft key, or selecting a Service. Mobile data can be used for opening a door, starting/stopping a machine etc. The data can either be predefined, or entered after the Hot key/Soft key is pressed or Service is selected.

The data can be predefined when programming the Soft/Hot key or Service, see [9.5.8 Edit a Soft key](#) on page 46 or [9.4.3 Edit a Service](#) on page 44.

5.13.2 Send Mobile Data with a Prefix

Mobile data with a prefix is sent from the handset by entering data and then pressing a pre-programmed Hot key or Soft key or select a Service. Mobile data with prefix can be used to send information to an application in the system. The prefix is predefined by the user when programming the Hot/Soft key or Service, see [9.5.8 Edit a Soft key](#) on page 46 or [9.4.3 Edit a Service](#) on page 44.

5.14 Conference Call

A conference call is indicated by a different signal compared to normal calls and a text message. The conference call must be answered within a pre-set time (default 30 seconds). A normal call in progress has higher priority, but if the normal call is ended

before the pre-set time, the conference call indication starts and the call can be answered.

Answer a Conference Call

Press the Call key  to answer. The handset is now dialling a dial-code and is connected to the group conference.

5.15 Call Setup Function

The call setup function includes the following features:

- Call number
This is the number that the handset calls when executing the call setup message. No call numbers will be stored in the call list.
- DTMF signalling
The handset is signalling DTMF tones after the call has been set up. If the Call number contains pauses, 'P', the digits after the first pause will be sent as DTMF signalling to the system.
- Text
This is the text that the handset displays when receiving a call setup message.
- Off-hook mode
 - Manual Off-hook:
The user must manually answer the message with one of the soft keys "Accept" or "Reject".
 - Automatic Off-hook:
The handset will automatically go off-hook.
If a call already is ongoing the call may be disconnected, depending on priority, and the call setup message will then be executed. (The user has the possibility to accept or reject the call within 10 s.)
If the call setup message could not be executed it is possible to manually execute it via the message list.
- Speaker mode
 - Off:
The speaker is disabled during the call.
 - Normal:
The normal speaker is used. If a headset is connected it will be active.
 - Loudspeaker:
The call starts in loudspeaking mode.
- Microphone mode
 - Push-To-Talk (PTT):
The mute button must be pressed and held in order to enable the microphone. When the mute button is released, the microphone is muted.
 - Microphone on:
Normal telephony mode.
- Priority
It is possible to prioritise call setup messages in the same way as with pagings and interactive messages. See [5.4 Prioritisation between Call Information and Messages](#) on page 21.
- Response
Defines that responses of call setup progress is requested. If response is enabled the

handset will automatically transmit statuses to the system when handling the call setup message.

Current statuses are:

- Accepted: the call setup message has been accepted.
- Rejected: the call setup message has been rejected.
- Completed: the call setup message has been handled.
- Failed: the call setup message failed..

- Beep
It is possible to assign a beep code to a call setup message in the same way as for a pagings and interactive message.
- Disconnect Mode
 - Manual:
The user must manually disconnect the ongoing call-setup initiated call.
 - Automatic:
The call-setup initiated call is automatically terminated when the call number has been dialled.

Note: Messages with "Off-hook Mode" and "Disconnect Mode" set to *Automatic* will not be stored in the Message List.

- TTL (Time-To-Live)
It is possible to define how long time a message is available in the Message List.
- Erase Message
It is possible to remotely erase a message and thereby disconnect an ongoing call.

Application Examples

It is possible to use the call setup functions in different ways, for example for Push-To-Talk (PTT), automatic phone call or speech monitoring.

5.15.1 Push-to-talk (PTT) using Call Setup

This example of packaging call setup functions orders several users to join "Push-To-Talk" group voice call (Microphone mode PTT).

The Push-To-Talk (PTT) function can be described as connecting a conference call with the microphone of the handset muted. The PTT function uses, instead of a PTT server, a phone number to some type of conference bridge (a specialized type of equipment that links telephone lines), see figure [figure 8](#) on page 27.

It is possible to configure groups using call setup in the system. These groups can be configured in any Unite module that handles groups.

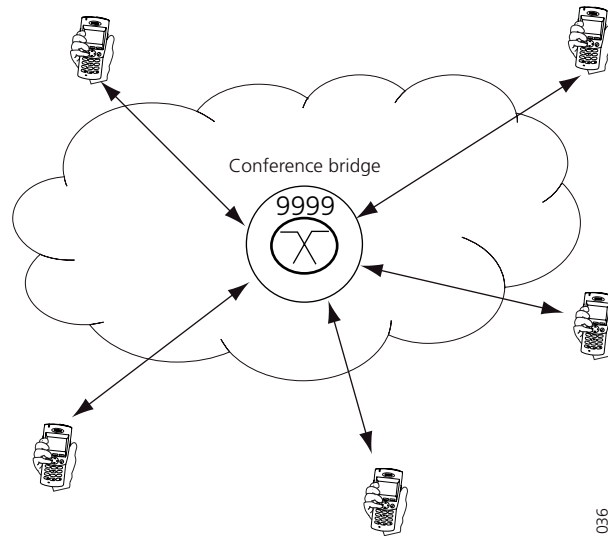

Figure 8. Simple PTT group call to a conference bridge.

A PTT session is triggered by an event, for example, an alarm from a person using a handset. It can also be triggered from a push of a button via a digital input. The event can also be initiated from a web interface like the Ascom NetPage or Open Access Toolkit (OAT) to create an own interface. An Ascom Alarm Management Server (AMS) or XGate is required in the system to generate the call setup that is sent to the handsets.

Note: The generic call setup message from the system can both be used for the PTT function or for getting the handset to automatically go off-hook, dial and then hang-up again.

PTT sessions are by default configured to open in loudspeaking mode but can be configured otherwise. The message sent to the PTT group members can include the possibility to accept or decline the PTT session, or a demand that it shall be accepted automatically.

Basically PTT is used to be able to have a group of people listening in, but without having their microphones enabled. Each user needs to take an action to enable their microphone and start sending voice data.

The mute button on the handset is used for sending voice and users have the possibility to talk simultaneously. Receiving is always active.

Accepting a PTT session will disconnect any ongoing call with the same or lower priority and cancel an ongoing PTT session. If it is configured to be accepted automatically and is received during an ongoing call or PTT session, a warning signal will sound 10 seconds in advance. During that time it is possible for the user to decline the new session. If declining the PTT session, it is possible to join later by selecting the PTT message stored in the message list. Leaving the PTT session is done by simply pressing the on-hook key.

Note: The PTT session is not interrupting anything with a higher priority (for example an alarm, call after alarm or emergency call).

See also [5.12.1 IM initiated Push-To-Talk \(PTT\)](#) on page 24 and [10.7 Push-To-Talk \(PTT\) via Hot Key](#) on page 57.

5.15.2 Application Controlled Dialling of Digits

This example of using call setup functions orders a handset to call a certain number for diversion of voice call (Answer mode automatic, Beep 0, Disconnect automatic).

When using this type of automatic dialling, for example, presence management, call forwarding and call pickup can be set.

Typically this is used when a system application controls the PBX functionality for a handset. The automatic dialling can be initiated by, for example, location, time or absence.

For further information about any of the above call setup examples, refer to system configurations of AMS or XGate.

6 Alarm Operation

Note: 9d24 MkII Protector only.

6.1 Push-button Alarm

Press the red alarm button twice within two seconds to activate the alarm. An information text is displayed, default "Personal Alarm" is displayed. The alarm is sent to the alarm central that distributes it further. After that the handset returns to stand-by mode. Note that you can always trigger the alarm when you are speaking, editing your settings, or while the phone is locked.

6.2 Test Alarm

Press and hold the red alarm button until the information text is displayed, default "Test Alarm" is displayed.

6.3 No-movement Alarm

Note: The stand-by time will decrease by approximately 25% when the handset is equipped with the Alarm Module.

You can activate/deactivate the alarm function in the menu, see [9.5.5 Deactivate/Activate No-movement alarm](#) on page 46, or by programming a Soft/Hot key as a shortcut to the function, see [9.5.8 Edit a Soft key](#) on page 46. To activate/deactivate in the handset require a a SIM card parameter setting. The Soft/Hot key changes the state of the alarm, i.e. if it is deactivated it will be activated and vice versa. Press the Soft key, or press and hold the Hot key, to put the alarm in operation respectively out of operation. The "No-movement alarm on" icon on your display is an indication that the No-movement alarm is in operation.

Send no-movement alarm

The No-movement alarm will go off when you have not moved within a preset time (default 30 seconds). Before the alarm is activated a warning signal sounds and the "No-movement on" icon starts to flash. If you do not cancel the alarm by pressing a key (or

the headset button if parameter is set), it is sent and “No-movement/man-down Alarm” is shown in the display.

Note: Even if the handset is locked (Phone Lock or Key pad lock), it is possible to press a key (or the headset button if parameter is set) to reset the warning signal.

Note: The alarm button can not be used to reset the warning signal.

Activate the no-movement alarm again

When the no-movement alarm has been sent, it is activated again by pressing a key or by moving the handset.

6.4 Pull-cord Alarm

Note: The handset has to be equipped with the optional Pull-cord alarm sensor. The 9d24 MkII ATEX/IECEx-Protector can not be equipped with Pull-cord alarm.

As an option a pull-cord can be attached to the handset. When the cord is removed an alarm is generated and sent. The alarm can be triggered immediately or after a delay of ten seconds. All depending on the parameter settings in the handset. You can activate/deactivate the alarm function in the menu, see [9.5.7 Deactivate/Activate Pull-cord alarm](#) on page 46, or by programming a Soft/Hot key as a shortcut to the function, see [9.5.8 Edit a Soft key](#) on page 46. To activate/deactivate in the handset require a a SIM card parameter setting. The Soft/Hot key changes the state of the alarm, i.e. if it is deactivated it will be activated and vice versa. Press the Soft key, or press and hold the Hot key, to put the alarm in operation respectively out of operation. The “Pull-cord alarm on” icon on your display is an indication that the Pull-cord alarm is in operation.

Send pull-cord alarm

The Pull-cord alarm will go off when the cord is removed. When the “Delay Pull-cord alarm” is selected, the alarm will not be sent if the pull-cord catch is fastened on the handset or the handset is placed in a charger within ten seconds. When the alarm has been sent “Pull-cord alarm” is shown in the display.

Note: The handset can be charged in the wall-mounted charger without removing the pull-cord catch.

Activate the pull-cord alarm again

When the pull-cord alarm has been sent, it is made active again by fastening the pull-cord catch on the handset. Attach the pull-cord catch to one side and then snap the other side into position, see [figure 9](#) below.

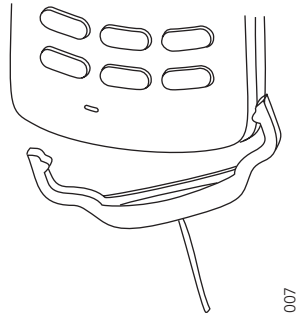

Figure 9. Fastening the pull-cord catch.

To avoid unintentional alarms, the catch has to be attached to the handset for 5 seconds before a new pull-cord alarm can be sent.

6.5 Man-down Alarm

Note: The handset has to be equipped with the optional Alarm Module.

You can activate/deactivate the alarm function in the menu, see [9.5.6 Deactivate/Activate Man-down alarm](#) on page 46, or by programming a Soft/Hot key as a shortcut to the function, see [9.5.8 Edit a Soft key](#) on page 46. To activate/deactivate in the handset require a a SIM card parameter setting. The Soft/Hot key changes the state of the alarm, i.e. if it is deactivated it will be activated and vice versa. Press the Soft key, or press and hold the Hot key, to put the alarm in operation respectively out of operation. The "Man-down alarm on" icon on your display is an indication that the Man-down alarm is in operation.

Send man-down alarm

The Man-down alarm will go off when the handset is tilted more than 45° for a preset time (default 30 seconds), for example if you fall. Before the alarm is activated a warning signal sounds and the "Man-down alarm on" icon starts to flash. If you do not cancel the alarm by pressing a key (or the headset button if parameter is set), it is sent and "No-movement/Man-down Alarm" is shown in the display.

Note: Even if the handset is locked (Phone Lock or Key pad lock), it is possible to press a key (or the headset button if parameter is set) to reset the warning signal.

Note: The alarm button can not be used to reset the warning signal.

Note: When the Man-Down alarm is triggered and the vibrator is enabled, the alarm signal is interrupted to sample the movement sensor. This is noticeable to the user and it is recommended to set the ringing period in the PBX to minimum acceptable time for the user and the time before warning before an alarm is sent from the handset, to maximum acceptable time for the user.

Activate the man-down alarm again

When the man-down alarm has been sent, it is made active again by moving the handset to upright position or pressing a key.

6.6 Acoustic Localisation Signal

A parameter in the handset determines whether or not an Acoustic Localisation Signal (ALS) should sound after a no-movement and man-down alarm. The ALS is silenced by pressing the Mute button.

6.7 Delay Time before Warning for No-movement and Man-down Alarms

By setting a SIM parameter, the time before the warning for no-movement and man-down alarms can be delayed for ten minutes, i.e. no-movement and man-down will not be detected during the time period. When the warning signal sounds, press the Mute button to delay the time to next warning for ten minutes.

6.8 Alarm with Data

Additional data for example a location code, can be sent along with an alarm. The data must manually be defined and stored by the user. To use the function, one Soft/Hot key in the handset must be defined as a shortcut to the menu "Edit alarm data", see [9.5.8 Edit a Soft key](#) on page 46. The stored data is added to all types of alarm at transmission. This is a system dependent function.

6.9 Automatic Call after an Alarm

Note: 9d24 MkII Protector only.

The handset can be programmed to call a predefined telephone number directly after an alarm. One Hot key in the handset must be programmed with the specific telephone number. It can be any external or internal telephone number but also a pre-defined group of handsets. The handset can be configured to call the same number for all types of alarms or to call different numbers depending on the alarm type.

A Hot key in the handset automatically is triggered when an alarm is activated. The specific Hot key must be programmed to dial the phone number, see [9.5.9 Edit a Hot key](#) on page 47.

This is a system dependent function that also require a SIM card parameter setting in the handset.

Note: An ongoing call will be disconnected, unless it is an alarm call, when the alarm is transmitted. Then the telephone number associated with the alarm will be dialled.

Note: If the function automatic call after an alarm is combined with the ALS function the speech will be muted in both directions. If the ALS is timed out during the call speech monitoring functionality will be activated. If the ALS is muted with the mute button the call will change into ordinary mode.

6.9.1 Connection method Speech Monitoring

Speech monitoring is the default connection method for an automatic call after an alarm.

The microphone on the handset that sends the alarm is discreetly activated in a highly sensitive mode and the speaker is muted. This will give the answering party opportunity to listen and to take an appropriate decision on how to act.

Areas of use are people working alone within fields like treatment of offenders, social work, medical care and psychiatry. It provides a high level of security and opportunity to survey the situation at the alarm site.

6.9.2 Connection method Loud

Changing the SIM parameter Call after alarm connection method will allow the automatic call after an alarm to be connected with loudspeaking function turned on.

6.9.3 Connection method Ordinary

Changing the SIM parameter Call after alarm connection method will allow the automatic call after an alarm to be connected in an ordinary way.

6.10 Alarm Management with Automatic Calls

In systems where messaging cannot be used for alarm transmission, automatic calls after alarm can be used to send the alarms to the system. In this case, the SIM parameter should be set so that Hot key 6 to 9 are associated with the different types of alarms.

Note: In these systems, the call will be disconnected automatically.

7 Navigate the Menu

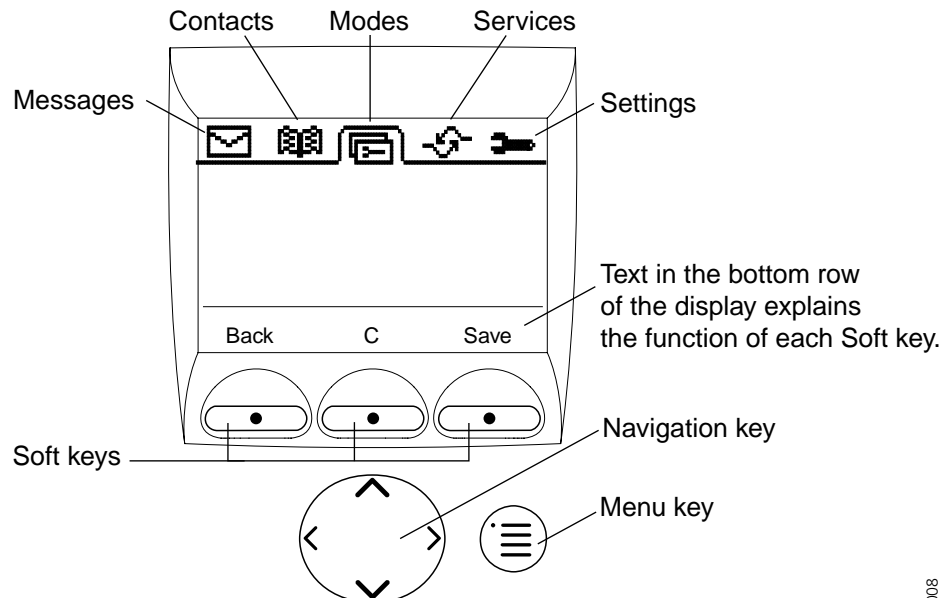



Figure 10. Menu tabs and the keys used for menu handling.

7.1 Enter/Exit the Menu Mode

Enter the menu by pressing the Menu key (☰) the last used tab is marked, or if the handset has been restarted, the menu tab Contacts .

Press Navigation key < or > to choose tab and press Navigation key ✓ to open it; a heading is shown and the first alternative is marked.

Press Navigation key ^ or v to step in the alternatives and select one by pressing Navigation key >.

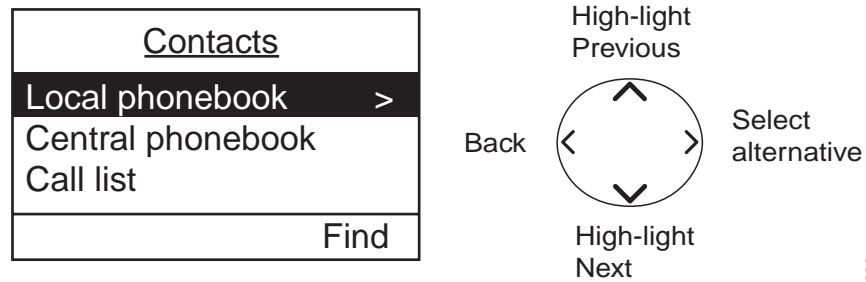

When you are in the Menu mode and have entered by pressing the Navigation key >, a press on Navigation key < takes you back one step. Navigation key < always takes you back one step when you have used Navigation key > to select an alternative. If you have entered by using a Soft key, press the left Soft key to step back.

The three Soft keys located just beneath the display is used for choices in the menu. The bottom row in the display is the Soft key field and the text in it gives you the function of each Soft key. Examples of functions are; Back, Exit, C (clear), Save, Delete, Options, Yes, No etc.

By pressing the Menu key (☰) again you will exit the Menu and return to stand-by mode.

8 Menu Tree

8.1 Messages Tab

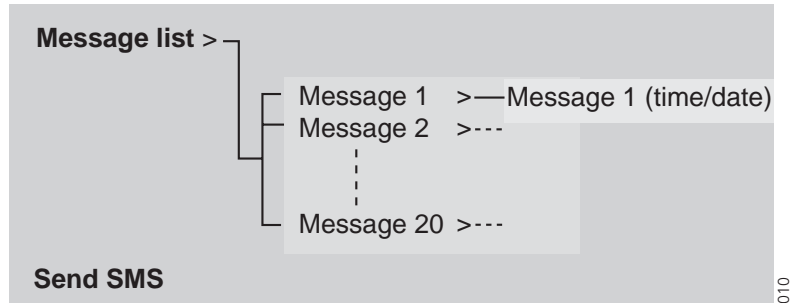

8.2 Contacts Tab

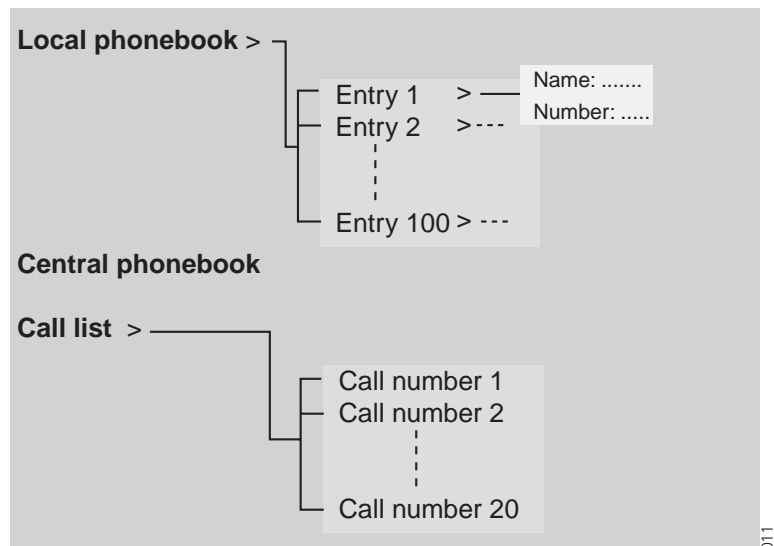

8.3 Modes Tab

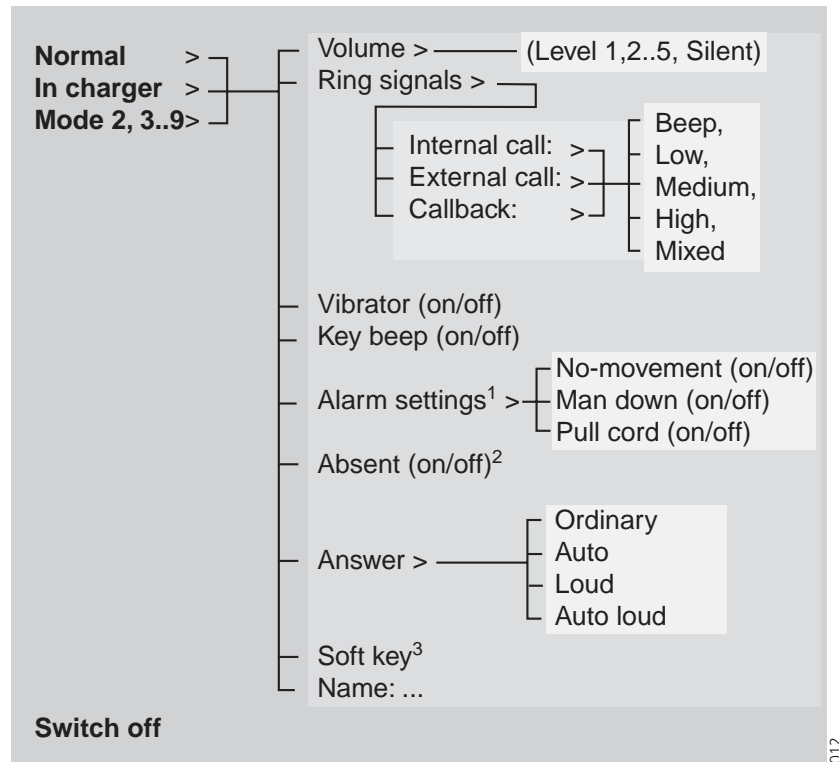

012

¹Only available in 9d24 MkII Protector versions.

²Not available in 9d24 MkII Talker versions.

³See [8.5 Settings Tab](#) on page 36 for more information.

8.4 Services Tab

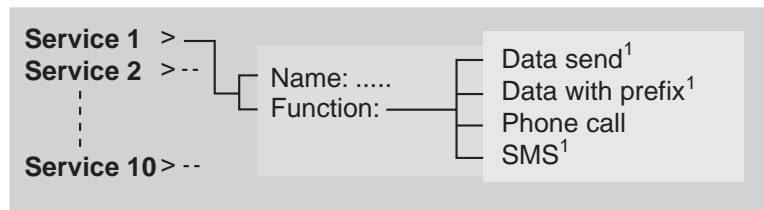

013

¹ Not available in 9d24 MkII Talker versions.

8.5 Settings Tab

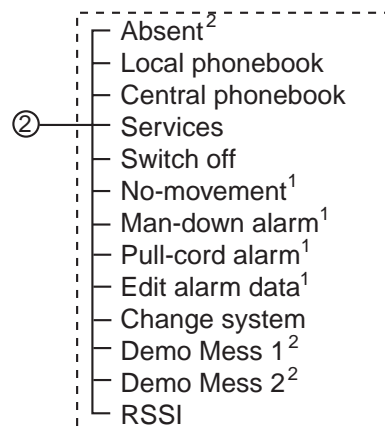
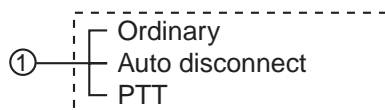
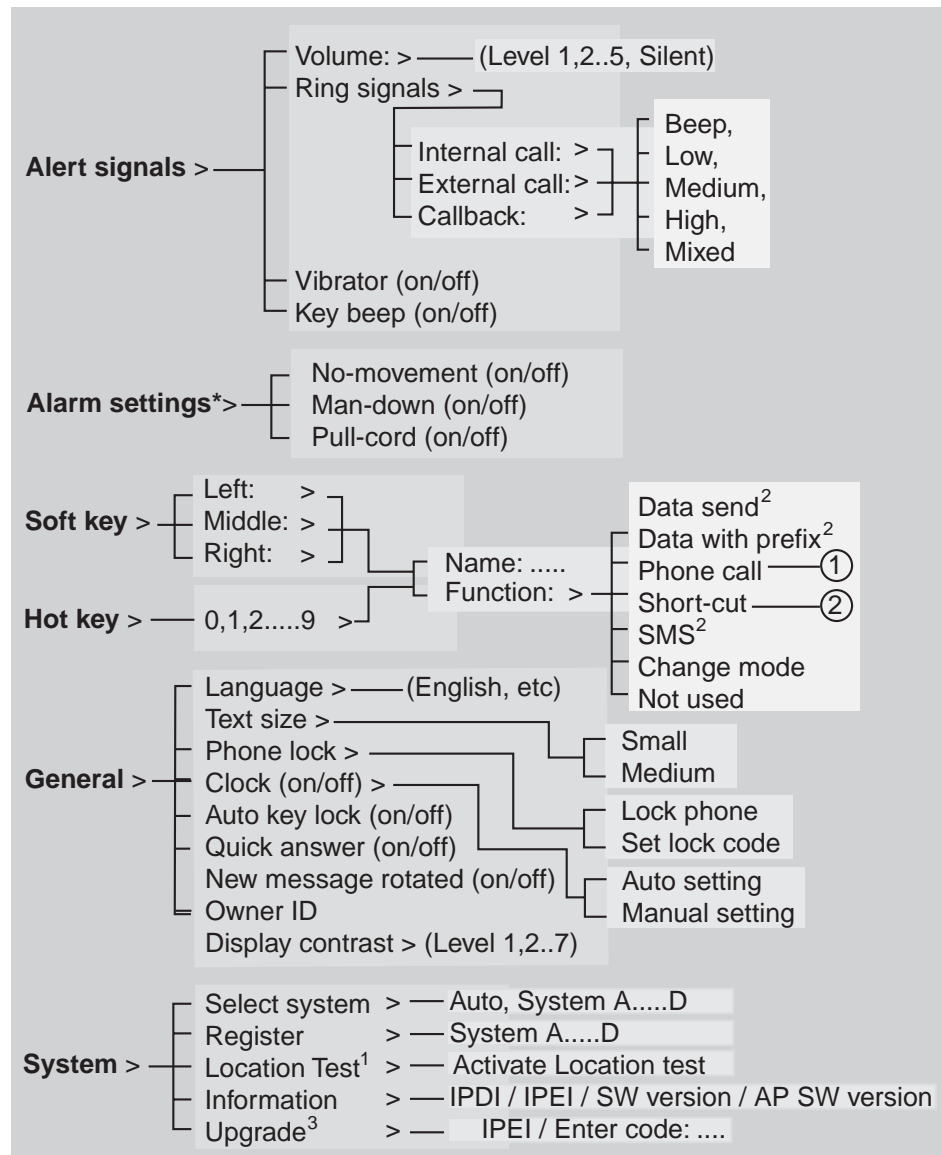

¹ Only available in 9d24 MkII Protector versions.
² Not available in 9d24 MkII Talker versions.
³ Not available in 9d24 MkII Protector versions.

8.6 Customizing the Menu Tree

The menu tree can be customized by hiding some of the functions that are available. Which functions that should be hidden are decided with settings in the SIM. The following functions can be hidden:

Deletion of messages	The options delete and delete all are hidden.
Administration of Local phonebook	It is not possible to add new entries, or edit and delete existing entries.
Editing modes	The settings for the modes cannot be altered.
Changing modes	The option select is hidden, i.e. it is not possible to change modes from the menu.
Switch off handset	It is not possible to switch off the handset from the modes menu.
Administration of Services	It is not possible to add new services, or edit and delete existing services.
Changing Alert Signals	The Alert Signals alternative in the menu is hidden.
Changing Alarm Settings	The Alarm Settings alternative in the menu is hidden.
Administration of Soft keys	The Soft key alternative in the menu is hidden.
Administration of Hot keys	The Hot key alternative in the menu is hidden.
Edit of Hot keys	The option edit is hidden. It is possible to see the settings for the Hot keys.
Changing General Settings	The General Settings alternative in the menu is hidden.
Handling Phone Lock	The Phone lock alternative in the menu is hidden.
Changing System ¹	The Select system alternative in the menu is hidden.
Register System ¹	The Register alternative in the menu is hidden.
Delete System	The option delete is hidden.
View Information ¹	The Information alternative in the menu is hidden.
Location test ¹	The Location test alternative in the menu is hidden.
Field Upgrade	The Upgrade alternative in the menu is hidden.
Central Phonebook address	When an address to the central phonebook is specified, the alternative Central Phonebook will appear in the Contacts menu and the shortcuts list. At delivery the address is set to 999999.

¹If all these alternatives are hidden the System alternative in the menu will be hidden.

Each mode in the menu can be hidden individually. This makes it possible to remove modes that are not used from the menu. Note that it is still possible to change to the hidden modes with help of Soft and Hot keys, see [9.5.8 Edit a Soft key](#) on page 46 for more information.

9 Menu Operation

A parameter setting in the SIM card determines if changes that are made from the menu is saved on the SIM card. If changes are not saved on SIM, they will be discarded when the handset is restarted.

9.1 Messages

- 1 Enter the menu by pressing the Menu key (☰).
- 2 Select the Message tab  to enter the Messages submenu.

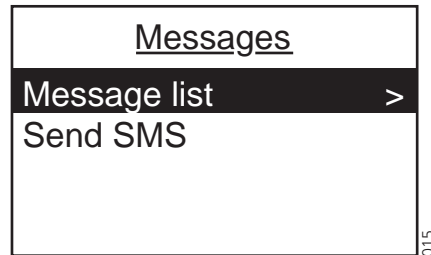

9.1.1 Message List

- 1 Mark the Message list and press the Navigation key > to see all received messages in the Message list.

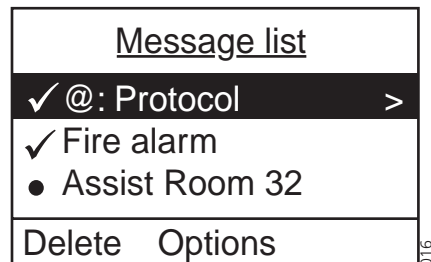

All received messages in the Message List is shown. The messages are either marked as read or unread.

- 2 Select a message by using the Navigation key ^ to mark the previous message and press Navigation key v to mark the next message in the message list.

View the message

- 1 Press the Navigation key >. The whole message is viewed and the date and time it was received is shown.
- 2 Press Navigation key < to return to the message list and "Exit" to return to the message list.

Delete the message

- 1 Open the desired message, see [9.1.1 Message List](#) and press "Delete"; the question "Delete message?" will appear.
- 2 Press "Yes". The handset will automatically return to the message list.

Delete all Messages

- 1 Open the desired message, see [9.1.1 Message List](#) and press "Options".
- 2 "Delete all" will appear. Press "Select"; the question "Delete all messages?" will appear.
- 3 Press "Yes" ("No" will take you back one step); "All messages deleted" is shown and after one second you will automatically be back in stand-by mode.

9.2 Contacts

- 1 Enter the menu by pressing the Menu key (☰).
- 2 Select the Contacts tab (☰). The alternatives in Contacts are; Local phonebook, Central phonebook and Call list.

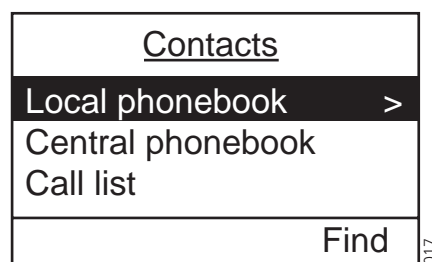

9.2.1 Find an Entry in the Local Phonebook



- 1 Select the Contacts tab (☰) and press the Navigation key (∨) to enter Contacts; the "Local phonebook" is marked.
- 2 Press "Find"; "Find:" will appear.
- 3 Enter the first letter in the name or the whole name. Press "Ok". The first name and number corresponding to your search will appear.
- 4 Press the Navigation key (∧) or (∨) to step to the next/previous entry. You can choose to delete or edit the entry. Press Navigation key (◀) to step back.

9.2.2 View an Entry in the Local Phonebook





- 1 Select the Contacts tab (☰) and press the Navigation key (∨) to enter Contacts.
- 2 Mark the "Local phonebook" and press Navigation key (➤). The first entry is marked.
- 3 Press the Navigation key (∨) to step in the list.
- 4 Press Navigation key (➤) to view the entry; the name and number will appear. Press Navigation key (◀) to step back.

9.2.3 Add an Entry to the Local Phonebook

- 1 Select the Contacts tab (☰) and press the Navigation key (∨) to enter Contacts.
- 2 Mark the "Local phonebook" and press Navigation key (➤). The first entry is marked.
- 3 Press "Add"; "Name:" and "Number:" will appear. The handset is in text input mode and the name can now be added. Change between upper and lower case characters by pressing the *- key on the keypad. The middle Soft key is used as a Clear (C) button.

- 4 Press Navigation key  and enter the number.
It is possible to turn on/off the tone sender in the entered number by making a long press on the *-key. Tone sender on will be indicated with a "T" in the number and off with "-". A pause can be added to the number by making a long press on the #-key. The pause is indicated with a "P" in the number. By using Navigation key  or  it is possible to step and add/delete a character/digit in the middle of a name/number.
- 5 Press "Save"; "Entry saved" is shown. The handset will automatically return to the local phonebook.



9.2.4 Delete an Entry in the Local Phonebook

- 1 Select the Contacts tab  and press the Navigation key  to enter Contacts.
- 2 Mark the "Local phonebook" and press Navigation key . The first entry is marked.
- 3 Press the Navigation key  to step in the list and mark the name you want to delete, Press "Options"; "Delete" is marked.
- 4 Press "Select"; the question "Delete entry?" will appear.
- 5 Press "Yes" ("No" will take you back one step); "Entry deleted" is shown. The handset will automatically return to the local phonebook.



You can also search or view an entry and delete it, see [9.2.2 View an Entry in the Local Phonebook](#) on page 39 and [9.2.1 Find an Entry in the Local Phonebook](#) on page 39.

- 1 Press "Delete" when the entry (name and number) is displayed; the question "Delete entry?" will appear.
- 2 Press "Yes" ("No" will take you back one step); "Entry deleted" is shown. The handset will automatically return to the local phonebook.

9.2.5 Edit an Entry in the Local Phonebook

- 1 Find or view the entry, see [9.2.2 View an Entry in the Local Phonebook](#) or [9.2.1 Find an Entry in the Local Phonebook](#).
- 2 Press "Edit" when the entry is displayed; the name and number will appear. First edit the name. Change between upper and lower case characters by pressing the *-key on the keypad. The middle Soft key is used as a Clear (C) button.
- 3 Press Navigation key  to edit the number. By using Navigation key  it is possible to step and add/delete a character/digit in the middle of a name/number.
- 4 Press "Save"; "Entry saved" is shown. The handset will automatically return to the local phonebook and the saved entry is marked.



9.2.6 Find an Entry in the Central Phonebook

- 1 Select the Contacts tab  and press the Navigation key  to enter Contacts.
- 2 Press Navigation key  and mark "Central phonebook".
- 3 Press "Find"; "Find:" will appear. Enter a name or number. Press "Ok". The search result is presented.







For more information about how to search in the Central phonebook, see *Installation and Operation Manual, DECT Phonebook Service, TD 92139GB*.

9.2.7 Save a Number from the Call List to the Local Phonebook







- 1 Select the Contacts tab  and press the Navigation key  to enter Contacts.

- 2 Press Navigation key  and mark "Call list" and open it by pressing the Navigation key . (This is the same call list that is reached by pressing Navigation key  in stand-by mode.) The first number in the list is marked.
- 3 Press the Soft key with the "Add contact" icon. The number is automatically added to the local phonebook and you only have to add the name. Change between upper case and lower case characters by pressing the *-key on the keypad. The middle Soft key is used as a Clear (C) button.
- 4 Press "Save"; "Entry saved" is shown. The handset will automatically return to the call list.



9.2.8 Delete a Number in the Call List

- 1 Select the Contacts tab  and press the Navigation key  to enter Contacts.
- 2 Press Navigation key  and mark "Call list"; open it by pressing the Navigation key . (This is the same call list that is reached by pressing Navigation key  in stand-by mode.) The first number in the list is marked.
- 3 Press Navigation key  and mark the number you want to delete.
- 4 Press "Options"; "Delete" is marked.
- 5 Press "Select"; "Number deleted" is shown. The handset will automatically return to the call list.

9.2.9 Delete All Numbers in the Call List

- 1 Select the Contacts tab  and press the Navigation key  to enter Contacts.
- 2 Press Navigation key  and mark "Call list"; open it by pressing the Navigation key . (This is the same call list that is reached by pressing Navigation key  in stand-by mode.) The first number in the list is marked.
- 3 Press "Options"; "Delete" is marked. Press Navigation key  and mark "Delete all".
- 4 Press "Select"; the question "Delete all numbers?" is shown.
- 5 Press "Yes" ("No" will take you back one step); "All numbers deleted" is shown. The handset will automatically return to stand-by mode.

9.3 Modes

- 1 Enter the menu by pressing the Menu key .
- 2 Select the Modes tab  and press the Navigation key  to enter Modes.

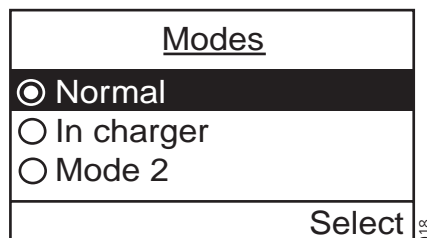

The handset is equipped with ten Modes. Two modes are preset at delivery and the remaining eight modes are left for the user to define. The preset modes are; Normal and In charger. The option Switch off is also located under the Modes tab .

Normal Mode

The Normal mode is the default mode.





In charger Mode

The In charger mode is activated when the handset is placed in the charger and deactivated when removed, it cannot be manually selected. Your last selected mode is automatically chosen when the handset is removed from the charger.

User defined Modes





Eight modes can be defined and saved by the user. The modes can, for example, be used to create a special headset mode with different ring signal volume and automatic answer of incoming calls. Another example is when several users are sharing the same handset. Each user can then define his/hers own settings, for example; type of ring signal, volume, answering method, Soft key settings etc. Note that one has to change to the user defined modes manually.

9.3.1 Change Modes

- 1 Select the Modes tab  and press the Navigation key  to enter Modes. A list with all modes is shown.
- 2 Press Navigation key  or  and mark the Mode you want to change to.
- 3 Press "Select"; the name of the marked Mode is shown. The handset will automatically return to the list.

A Soft/Hot key can be programmed to change modes, see [9.5.8 Edit a Soft key](#) on page 46 for more information.

9.3.2 Change Mode Settings



- 1 Select the Modes tab  and press the Navigation key  to enter Modes. A list with all modes is shown.
- 2 Press Navigation key  or  and mark the Mode you want to change the settings in.
- 3 Press Navigation key  to view the settings. The handling is then according to the ordinary settings, see [9.5 Settings](#) on page 45, but you also have the possibility to set Absent On/Off, choose answering method and give the mode a new name.

9.3.3 Set the Mode to Absent On/Off

- 1 Follow the instructions described in [9.3.2 Change Mode Settings](#) and view the modes settings.
- 2 Press the Navigation key , mark "Absent" and press "Change"; the Absent checkbox is marked/unmarked.





9.3.4 Choose the Modes Answering method

- 1 Press the Navigation key , mark "Answer:" and press Navigation key .

- 2 Press Navigation key  and choose the answering method you want. You can choose; Ordinary, Auto, Loud or Auto loud.
 - Ordinary; press the Call key  or the middle Soft key for loudspeaking function.
 - Auto; the call is automatically connected.
 - Loud; press the Call key  and the call is connected with loudspeaking function turned on.
 - Auto loud; the call is automatically connected with loudspeaking function turned on.

When you have chosen type of answering method, press "Select"; the name of the selected method is shown. The handset will automatically return to the list and the new answering method is marked.

9.3.5 Switch the Handset Off

- 1 Select the Modes tab  and press the Navigation key  to enter Modes. A list with all modes and the switch off option is shown.
- 2 Press Navigation key  or  and mark "Switch off"; press "Select". Step to "Yes" and press "Ok" and the handset switches off.

Or:

Program a Soft/Hot key to switch the handset off, see [9.5.8 Edit a Soft key](#) on page 46. When the preprogrammed Soft key or Hot key is pressed "Switch off" is shown. Step to "Yes" and press "Ok" and the handset switches off.

9.3.6 Customizing the Modes Menu

It is possible to set that a mode should not be shown in the list. This is an easy way to hide modes that are not used. A setting in the SIM determines whether the mode should be in the list or not.

9.3.7 Change Mode Remotely

Depending on parameters, it is anytime possible to set the mode of a handset remotely by sending a new message to the handset.

When the mode is changed the following happens to a handset:

- The warning signal before an alarm gets off, is stopped
- The Automatic Location Signal (ALS) will continue even after mode change
- The volume of the ring signal may change

9.4 Services



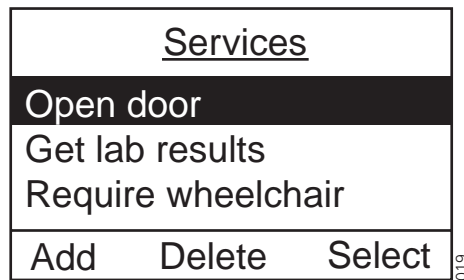

Note: Not available in 9d24 MkII Talker versions.

- 1 Enter the menu by pressing the Menu key.
- 2 Select the Services tab ; a list with all created Services is shown.



- 3 Press the Navigation key  to enter Services.









9.4.1 Activate a Service

- 1 Select the Services tab  and press the Navigation key  to enter services.
- 2 Press Navigation key  or  and mark the Service you want to activate.
- 3 Press "Select"; the service will be activated. If data is sent, the text "Sending" is shown. The handset will automatically return to the list and the selected service is marked.





9.4.2 Create a new Service

- 1 Select the Services tab  and press the Navigation key  to enter services.
- 2 Press "Add"; "Name:_" is displayed.
- 3 Enter a name that describes the service you want to add, for example, if you want this service to open a door, then name it "Open door". Press "Save"; the new name is marked and added to the list.
- 4 Press Navigation key ; "Function:Not used" is marked. Press "Change" to enter functions. The functions available are; Data send, Data with prefix, Phone call and SMS. Choose the function you want the service to have and press "Select".
- 5 Enter data, prefix, phone number, or SMS address and text; press "Ok" to save the setting. The handset will automatically return to the service and the function is marked.

9.4.3 Edit a Service

- 1 Select the Services tab  and press the Navigation key  to enter services. A list with all Services is shown.
- 2 Press Navigation key  or  and mark the one you want to edit.
- 3 Press Navigation key  and then "Edit" to change the name. Change the name and press "Save". Press Navigation key  and press "Change". Choose a function and press "Select".
- 4 Enter data, prefix, phone number, or SMS address and text; press "Save". The handset will automatically return to the service and the function is marked.

9.4.4 Delete a Service

- 1 Select the Services tab  and press the Navigation key  to enter services. A list with all Services is shown.
- 2 Press Navigation key  or  and mark the one you want to delete.
- 3 Press "Delete"; the question "Delete service?" is shown.
- 4 Press "Yes"; "Entry deleted" is shown for 1 second. The handset will automatically return to the list and the next Service is marked.

9.5 Settings

- 1 Enter the menu by pressing the Menu key. (☰)

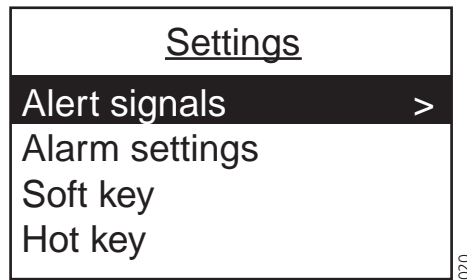







The alternatives in Settings are; Alert signals, Alarm settings, Soft key, Hot key, General and System.

- In Alert signals you can change your settings for all audible signals and the vibrator.
- Alarm settings are only available for the Protector versions with alarm option pack and/or pull-cord alarm option.
- In Soft key and Hot key you can assign the Soft/Hot key a function.
- In General you can change following settings: Language, Text size, Clock, Auto key lock, Quick answer, New message rotated and Owner ID.
- In System you can Select system, Register a new system* and get information about the handset.

* See [10.1 System Handling](#) on page 50.







9.5.1 Change the Volume

- 1 Select the Settings tab  and press the Navigation key  to enter Settings.
- 2 Mark "Alert signals" and press Navigation key .
- 3 Mark "Volume:" and press Navigation key .
- 4 Press Navigation key  and choose the volume you want. There are six available alternatives; Level 1 to 5, or Silent.

If you want to hear the volume level during the changing, press "Play". The handset will play until you press "Stop", "Select", or Navigation key .

Activate your choice by pressing "Select"; the selected volume is shown. The handset will automatically return to the Alert signals list and the volume is marked.



9.5.2 Change the Ring Signal

- 1 Select the Settings tab  and press the Navigation key  to enter Settings. Mark "Alert signals" and press Navigation key .
- 2 Mark "Ring signals" and press Navigation key . You can change the ring signal for Internal call, External call, or Call back.
- 3 Press Navigation key  and choose the ring signal you want to change by pressing Navigation key .
- 4 Press Navigation key  and choose the signal you want. Available alternatives are; Beep, Low, Medium, High and Mixed.



If you want to hear the new signal, press "Play". The marked signal is played until you press "Stop", "Select", or Navigation key .

- 5 Activate your choice by pressing "Select"; the selected Ring signal is shown. The handset will automatically return to the Ring signals list and the changed Ring signal is marked.



9.5.3 Key Beep On/Off

- 1 Select the Settings tab  and press the Navigation key  to enter Settings.
- 2 Mark "Alert signals" and press Navigation key .
- 3 Mark "Key beep" and press "Change"; the Key beep checkbox is marked/unmarked.



9.5.4 Vibrator On/Off

- 1 Select the Settings tab  and press the Navigation key  to enter Settings.
- 2 Mark "Alert signals" and press Navigation key .
- 3 Mark "Vibrator" and press "Change"; the Vibrator checkbox is marked/unmarked.



9.5.5 Deactivate/Activate No-movement alarm

- 1 Select the Settings tab  and press the Navigation key  to enter Settings.
- 2 Mark "Alarm settings" and press Navigation key .
- 3 Mark "No-movement" and press "Change"; the No-movement checkbox is marked/unmarked.

9.5.6 Deactivate/Activate Man-down alarm



- 1 Select the Settings tab  and press the Navigation key  to enter Settings.
- 2 Mark "Alarm settings" and press Navigation key .
- 3 Mark "Man-down" and press "Change"; the Man-down checkbox is marked/unmarked.

9.5.7 Deactivate/Activate Pull-cord alarm

- 1 Select the Settings tab  and press the Navigation key  to enter Settings.
- 2 Mark "Alarm settings" and press Navigation key .
- 3 Mark "Pull-cord" and press "Change"; the Pull-cord checkbox is marked/unmarked.

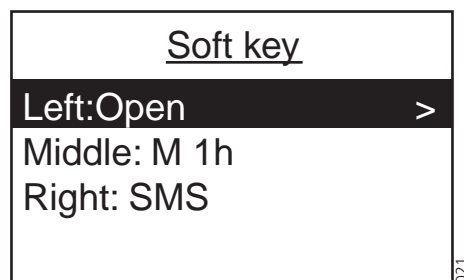
9.5.8 Edit a Soft key



- 1 Select the Settings tab  and press Navigation key  to enter Settings.
- 2 Mark "Soft key" and press Navigation key .

- 3 Mark the one you want to edit and press Navigation key >.
- 4 Press "Edit"; "Name;_" is displayed.
- 5 Enter a name of maximum seven characters. Press "Save". "Changes saved" is shown and the handset automatically returns to the Soft key.
- 6 Press Navigation key ∨; "Function:....." is marked. Press "Change" to enter functions.
- 7 Press Navigation key ∨ and choose the function you want the Soft key to have.

Functions:

- Data send: Press "Select". Enter data if you want to predefine it, or leave it out if you want to enter data after pressing the Soft key, press "Save".
- Data with prefix: Press "Select". Enter prefix and press "Save".
- Phone call: Press "Select". Choose how to end the call, Ordinary, Auto disconnect or PTT. Press "Select". Enter phone number and press "Save".
It is possible to turn on/off the tone sender in the entered number by making a long press on the *-key. Tone sender on will be indicated with a "T" in the number and off with "-". A pause can be added by making a long press on the #-key. The pause is indicated with a "P" in the number.
- Shortcut: Press "Select". Assign the shortcut; Absent, Local phonebook, Central phonebook, Services, Switch off, No-movement alarm, Man-down alarm, Pull-cord alarm, Edit alarm data, Change system, Demo Mess 1, Demo Mess 2, or RSSI. Press "Select".
- SMS: Press "Select". When "SMS address" is shown you can leave it blank, or you can predefine a destination address; press "Ok".
- Change mode: Press "Select". Mark the mode that should be changed to and press "Select".
- Not used: Press "Select". "Not used" will be indicated in the Soft key list.







The name of the selected function is shown. The handset will automatically return to the Soft key.

9.5.9 Edit a Hot key





- 1 Select the Settings tab  and press Navigation key ∨ to enter Settings.
- 2 Mark "Hot key" and press Navigation key >.
- 3 Mark the one you want to edit (0, 1, 2,.....9) and press Navigation key >.
- 4 "Name:" is marked; press "Edit".
- 5 Enter a name of maximum sixteen characters. Press "Save". "Changes saved" is shown and the handset automatically returns to the hot key.
- 6 Press Navigation key ∨; "Function:....." is marked. Press "Change" to enter functions.
- 7 Press Navigation key ∨ and choose the function you want the Hot key to have. The functions for a Hot key are the same as for a Soft key, see table under [9.5.8 Edit a Soft key](#) on page 46.

Note: The SIM parameter enabling this function can be disabled by your system administrator.

9.5.10 Select Language





- 1 Select the Settings tab  and press the Navigation key  to enter Settings.
- 2 Step to "General" and press Navigation key .
- 3 Mark "Language" and press Navigation key . Step in the list by using Navigation key  or .
- 4 Press "Select". The language is shown. The handset will automatically return to the list of general settings.

9.5.11 Change Text Size





- 1 Select the Settings tab  and press the Navigation key  to enter Settings.
- 2 Step to "General" and press Navigation key .
- 3 Press Navigation key  and mark "Text size".
- 4 Press Navigation key  and choose between Small and Medium. Press "Select". Small/Medium is shown and the handset automatically returns to the list of general settings.

Note: The 9d24 MkII ATEX/IECEX-Messenger and 9d24 MkII ATEX/IECEX-Protector can only show Medium Text Size.

9.5.12 Lock the Handset Manually





- 1 Select the Settings tab  and press the Navigation key  to enter Settings.
- 2 Step to "General" and press Navigation key .
- 3 Press Navigation key  and mark "Phone lock". Press Navigation key  and mark "Lock phone". Press "Select" and the handset is locked.

9.5.13 Change the Lock Code



- 1 Select the Settings tab  and press the Navigation key  to enter Settings.
- 2 Step to "General" and press Navigation key .
- 3 Press Navigation key  and mark "Phone lock". Press Navigation key  and mark "Set lock code". Press "Select".
- 4 Enter the new lock code and press "Save".



9.5.14 Clock Settings

Set the Clock to get the Time Automatically from the System

- 1 Select the Settings tab  and press the Navigation key  to enter Settings.
- 2 Step to "General" and press Navigation key .
- 3 Press Navigation key  and mark "Clock".
- 4 Press Navigation key  and mark "Auto setting". Press "Select". Auto setting is shown and the handset automatically returns to the list of general settings.





Set the Clock Manually

- 1 Select the Settings tab  and press the Navigation key  to enter Settings.
- 2 Step to "General" and press Navigation key .



- 3 Press Navigation key  and mark "Clock".
- 4 Press Navigation key  and mark "Manual setting". Press "Select". Enter time, year, month and day according to the example below; press "Save".

Example: Time:0815, Year:2002, Month:03, Day:30.





Set the Clock to be Visible/Invisible in Stand-by Mode

- 1 Select the Settings tab  and press the Navigation key  to enter Settings.
- 2 Step to "General" and press Navigation key .
- 3 Press Navigation key  and mark "Clock". Press "Change". The Clock checkbox is marked/unmarked.





9.5.15 Turn On/Off Automatic Keypad Lock

- 1 Select the Settings tab  and press the Navigation key  to enter Settings.
- 2 Mark "General" and press Navigation key .
- 3 Mark "Auto key lock" and press "Change". The Auto key lock checkbox is marked/unmarked. In stand-by mode a locked keypad is indicated by the "Locked keypad" icon.

9.5.16 Enable/Disable Quick Answer

- 1 Select the Settings tab  and press the Navigation key  to enter Settings.
- 2 Step to "General" and press Navigation key .
- 3 Press Navigation key  and mark "Quick answer". Press "Change". The Quick answer check box is marked/unmarked.





9.5.17 Set New Messages to be Displayed Upside down

- 1 Select the Settings tab  and press the Navigation key  to enter Settings.
- 2 Step to "General" and press Navigation key .
- 3 Press Navigation key , step to "New message rotated" and press "Change". The New message rotated checkbox is marked/unmarked.

When this parameter is set, the call information for incoming calls is also displayed upside down.

Note: If an interactive message or a message with manual acknowledge is received, the soft-key alternatives are hidden until a button is pressed and the message is rotated to "standard view".

9.5.18 Set Owner ID

- 1 Select the Settings tab  and press the Navigation key  to enter Settings.
- 2 Step to "General" and press Navigation key .
- 3 Step to "Owner ID" with Navigation key  and press "Edit".
- 4 Enter a name and press "Save". Change between upper and lower case by pressing the *-key on the keypad. The new ID is shown. The handset will automatically return to the list of general settings.

9.5.19 Select PBX System

- 1 Select the Settings tab  and press the Navigation key \surd to enter Settings.
- 2 Step to "System" and press Navigation key \sphericalangle .
- 3 Mark "Select system" and press Navigation key \sphericalangle .
- 4 Press Navigation key \wedge or \sphericalangle , mark system and press "Select". "System selected" is shown. The handset will automatically return to the system menu.

Select PBX System Set as a Hot key

If you are often moving between systems, it might be convenient to change system quickly, therefore you can set this function as a Soft key, or Hot key.

To change systems: just press the pre-programmed Soft/Hot key to connect to the next available PBX system (A, B, C or D). See [Rename a system](#) on page 51 on how to change the system name.

9.6 Additional Information

To obtain general information about the handset select the Settings tab  in the menu. Press Navigation key \sphericalangle , step to "System" and press Navigation key \sphericalangle . Press Navigation key \sphericalangle and step to "Information". Press Navigation key \sphericalangle to view information about:

- IPDI: The unique global GAP identity number for the SIM card.
- IPEI: The unique global GAP identity number for the handset.
- SW version: Here you can see which version of the handset software you have.
- AP SW version: The Alarm Module software. If the Alarm Module is not connected, it will be indicated with NC (Not Connected).

Tip: There is a quick access code you can use to enter the information mode directly without using the menu. The quick access code is ***#46#**.

10 Advanced Functions

10.1 System Handling

The 9d System supports the GAP (Generic Access Profile) standard. This makes it possible to log on to any GAP compatible system with your handset.

10.1.1 Register a New PBX System

You can register up to four different PBX systems on your handset. To register you have to enter the authentication code related to the system you are logging on to.



Note: To avoid deleting a registered system accidentally, a parameter can be set in the SIM card that makes it impossible for the normal user to delete a system.

When you have registered more than one system, you can manually select which system to connect to, see [9.5.19 Select PBX System](#) on page 50.

Register

- 1 Enter registration mode.
Enter the menu and press Navigation key < or > to select the Settings tab  and press the Navigation key ∨ to enter "Settings". Press Navigation key ∨, step to "System" and press Navigation key >. Select "Register" and press Navigation key >. Step to the next available PBX system, system A, B, C or D and press "New".
Tip: There is a quick access code you can use to enter the register mode directly without using the menu. The quick access code is *#73#.
- 2 Press "C" to delete the default name. Use the Alpha Numeric Keys to write a name, maximum 12 letters. Press "Ok".
Or press "Ok" to accept the default name.
- 3 The IPDI code is displayed. The GAP identity number for the SIM card can be required in some PBXs. Press "Ok".
- 4 "Park:" is displayed. The PBX Park number is only needed if it is difficult to register to a specific PBX when you have several PBXs. Press "Ok".
- 5 Enter the authentication code related to the new PBX system and press "Ok".
"Searching" is displayed. If the handset has found the new system "Registering OK" is displayed. If the handset fail to find the new system "Registering fail" is displayed.

Rename a system

- 1 Enter the menu  and press Navigation key < or > to select the Settings tab .
- 2 Press the Navigation key ∨ to enter "Settings". Press Navigation key ∨, step to "System" and press Navigation key >.
- 3 Select "Register" and press Navigation key >. The PBX system you are logged on to is marked.
- 4 Select "Name". Press "C" to remove the current name. Enter a new name.

10.2 Adjustment of Audio Parameters

The handset is delivered with a set of audio parameters with standard settings for best audio quality. In some environments, for example one with a high noise level, these standard values might have to be adjusted to get good audio quality. There are different SIM card parameters for audio parameters for normal conversation and when loudspeaking function or headset is used.

In order to achieve optimal audio quality with the different headset types it is recommended that the SIM parameter called "Headset type" is altered to match the headset type being used. The default setting for this parameter is microphone on a boom i.e. the audio is optimized for using a headset with microphone on a boom.

10.3 DECT Location Feature

The 9d24 MkII Protector can be equipped with the DECT Location feature that gives location information when an alarm is sent. A setting in the SIM card activates location. There is also a separate parameter that activates "Special location", i.e. an alarm is sent every time the handset gets a location from a Location Device with "Immediate Alarm Transmission" enabled.





There are three options to indicate that the handset is within the range of a location device:

- The display lights up.
- The LED lights up.
- A beep.

The 9d24 MkII ATEX/IECEx-Protector is equipped with the DECT Location feature by default.

10.3.1 Location Test

When a DECT Location system is installed, a handset with this feature has to be used for location test.

- 1 To activate the location test mode, select the Settings tab  and press Navigation key  to enter settings.
- 2 Step to "System" and press Navigation key .
- 3 Select "Location test" and press Navigation key .
- 4 Press "Ok" to activate the location test. To deactivate the location test, press "Ok" again.

10.3.2 Location Request

Depending on settings, it is possible for a system with the DECT Location function, to request the latest location of a handset whenever it is required. For Protector versions, it is possible to see the current base station and up to the four latest 9dLD Location Devices. For Messenger versions, it is possible to see the current base station.

Note: In a system without DECT Location it is always possible to request the latest base station. Not applicable to the Talker version.





10.4 Field Upgrade

The 9d24 MkII Messenger and 9d24 MkII Talker can both be upgraded. The 9d24 MkII Messenger can be upgraded to a 9d24 MkII Protector and the 9d24 MkII Talker can be upgraded to a 9d24 MkII Messenger or a 9d24 MkII Protector. Specific upgrade packages have been created and are available for ordering.

The 9d24 MkII ATEX/IECEx-Messenger can not be upgraded to 9d24 MkII ATEX/IECEx-Protector.

10.4.1 Upgrade

When you have received the upgrade package, download a licence code from our Extranet and upgrade your handset as follows:

- 1 Use your handset and enter the upgrade mode: Select the Settings tab  and press Navigation key  to enter Settings. Mark "System" and press Navigation key . Press Navigation key  and mark "Upgrade". Press Navigation key .
Tip: There is a quick access code you can use to enter the upgrade mode directly without using the menu. The quick access code is *#87#.
- 2 Go to the upgrade service on our Extranet and enter the IPEI number and the access code for the handset. The IPEI number is shown in your handset when entering the upgrade mode. The access code is included in the upgrade package.

- 3 When you have received the licence code, enter the licence code in the upgrade mode on your handset and press "Ok". A message is shown in the display telling you if your handset has been upgraded or not. Additional functions have now been added to your handset. The functions can be used immediately without having to restart the handset.
- 4 The upgrade package contains a new top front for the handset. To replace the existing top front on the handset with the new one, do as follows:
Release the two screws at top on the handset and lift off the top front, see [figure 11](#) and [figure 12](#). Mount the new top front on the handset and fasten it with two screws, see [figure 13](#), [figure 14](#) and [figure 15](#).

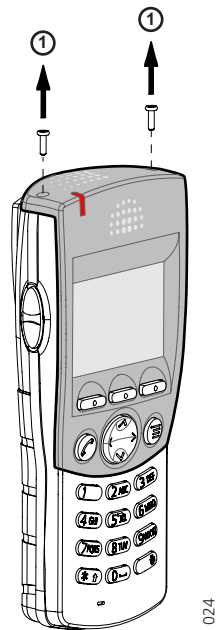
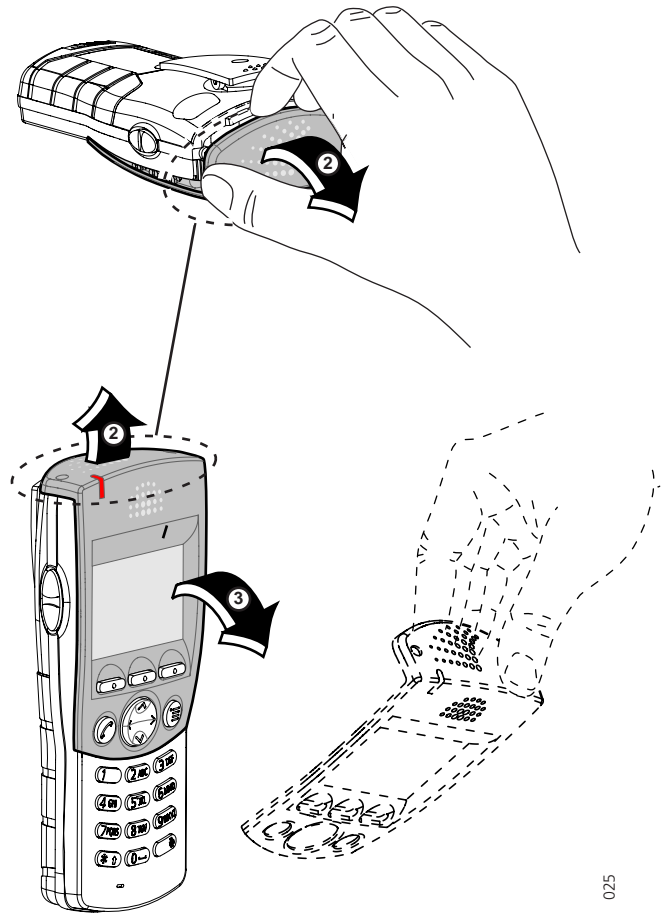
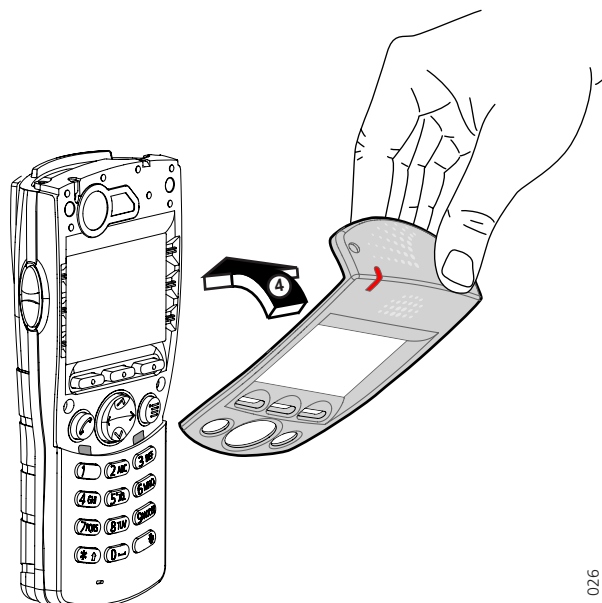

Figure 11. Release the two screws at top on the handset.



025

Figure 12. Take hold of the upper part of the top front and slightly lift it (2) so that the top front starts to come off from the handset. Remove the top front (3).



026

Figure 13. Put the new top front in place on the handset.

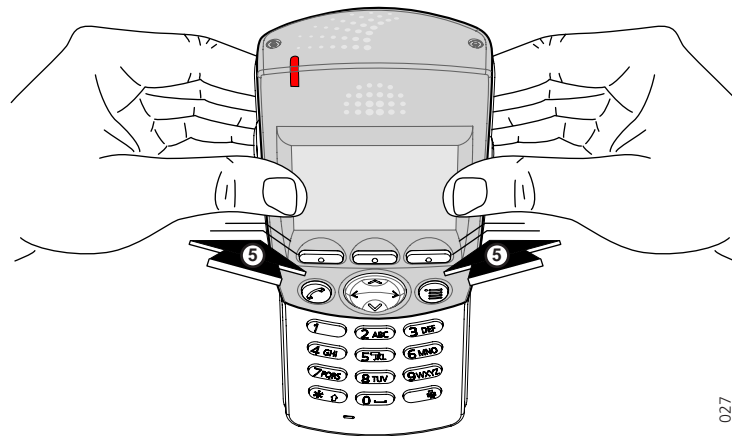

Figure 14. Make sure that the top front is well mounted. Press with your thumbs on the top front as shown in figure 14 and figure 15 (below).

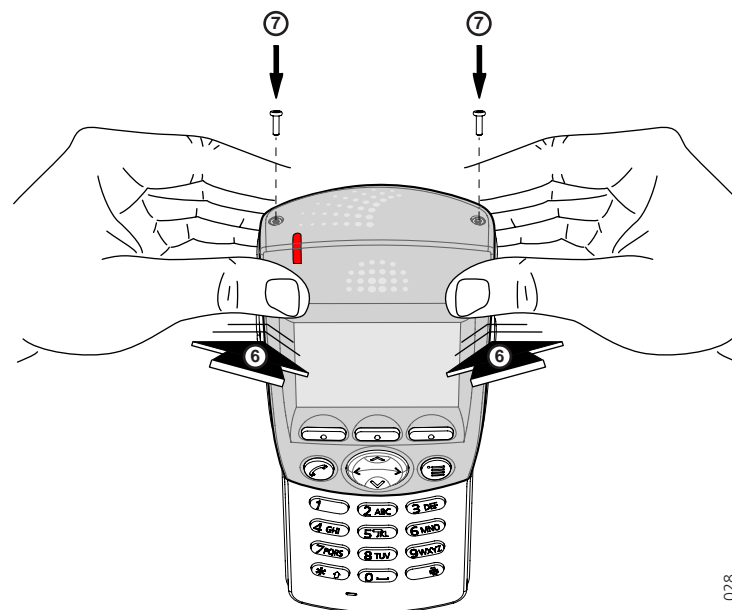

Figure 15. Fasten the top front with two screws.

10.5 Updating Software

There are two ways to update the 9d24 MkII software, either by downloading an intel hex file from a computer or by copying the software from one handset to another. Current software version can be found in the settings in the handset, see [9.6 Additional Information](#) on page 50.

For maximum update speed make sure that the com port used supports 230400 bits per second or use the handset to handset copying method. A software update at maximum speed takes about 30 seconds.

Note: Updating the software does not change existing parameters in the handset.

10.5.1 Downloading Software

To be able to download the 9d24 MkII software a Desktop Programmer for 9d24 is needed. The desktop programmer is delivered with a Power Supply and a CD containing required software and documentation.

Desktop Programmer for 9d24 Art.No: DC2-1011

10.5.2 Copying Software

The 9d24 MkII software can be copied from one handset to another by using a modified CR24 Charging Rack for 9d24. The charging rack can be ordered separately and modified as described in the CR 24 Installation Guide

Charging Rack Module Art.No: 651062

Power Supply Module Art.No: 651063

Copying procedure

- 1 Remove the battery pack on the master handset (i.e. the handset with the software that is to be copied).
- 2 Press and hold down key 1 on the handset while replacing the battery pack again. Do not release key 1 until "Wait..." appears in the display.
- 3 When "Wait..." disappears, place the handset in the master slot on the charging rack, see [figure 16](#) on page 56. Make sure that the handset locks into position.
- 4 Remove the battery pack on the slave handset (i.e. the handset that is to be updated).
- 5 Press and hold down key 4 on the handset while replacing the battery pack again. Do not release key 4 until "Load SW:...Exit" appears in the display.
- 6 Place the handset in the slave slot to the left of the master slot, see figure below. Make sure that the handset locks into position. "Erase memory" is shown in the slave handset display. Then the copying process starts.

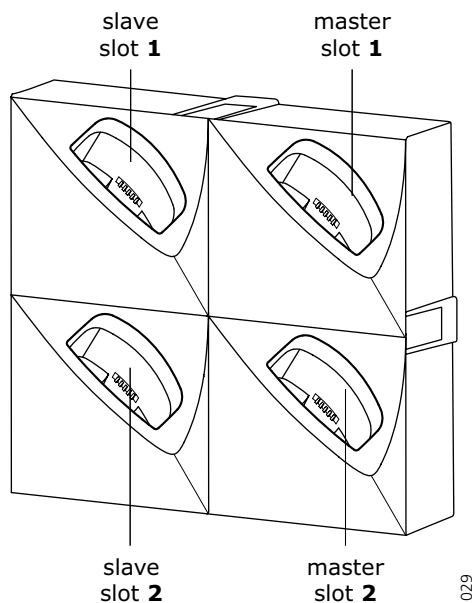

Figure 16. Master and slave slots in a CR24 Charging Rack for copying of software.

When "Ok" appears in the bottom of the display the copying is finished.

If the copying was not successful "Fail" will appear in the display. Remove the handset from the charging rack and repeat from point 4.

- 7 Remove the handset from the charging rack. "Exit Ok" is shown in the display. Press volume key up to start up the handset. To continue copying software to additional slave handsets, keep the master handset in the charging rack and repeat from point 4.
- 8 When the copying procedure is finished remove the master handset from the charging rack. Press volume key up to start up the handset.

10.6 Changing SIM parameters

The SIM card parameters can be altered from the handset but also by using a SIM Card Programmer. To be able to give the same parameter settings to several handsets the parameters can be saved to file from the SIM Card Programmer. The file can also be used to reset the parameters in a handset to default values. The SIM Card Programmer is delivered with a CD containing required software.

SIM Card Programmer for 9d23 and 9d24 Art.No: 651041

10.7 Push-To-Talk (PTT) via Hot Key

There are two different types of Push-To-Talk (PTT) functions that are set by SIM card parameters in the handset. For both variants the Mute button has to be pressed during conversation.

The first push-to-talk function can be described as a group call/conference call. To enter the group call the members must press a Soft/Hot key with a pre-programmed dial-code. If one of the group members wants to get in contact with the others, he/she simply presses and holds the Mute key to open the microphone. The microphone is muted again when the Mute key is released. The dial-code is set in the Soft/Hot key as a "Phone number". To set the "Phone number" see chapter [9.5.8 Edit a Soft key](#) on page 46.

Note: When this function is enabled all calls started with a Soft key or Hot key will be using the push-to-talk function.

The second push-to-talk function is used in DECT systems that are connected to systems where only one person is allowed to speak at the same time. The handset sends DTMF tones to the connected system when the Mute button is pressed/released to open/close the speech channel.

See also [5.12.1 IM initiated Push-To-Talk \(PTT\)](#) on page 24 and [5.15.1 Push-to-talk \(PTT\) using Call Setup](#) on page 26.

11 Maintenance

11.1 Charge the Battery

The battery requires charging when the battery icon in the handsets display is empty.

Place the handset in the charger. A beep indicates connection with the charger. The charging status is shown by the battery icon in the handset display. After approximately

two (Desktop Charger) / four (Charging Rack) hours the handset is fully charged, indicated by a filled battery icon.

If the handset is switched off automatically due to low battery and placed in a charger the handset will be switched off but charged. The charging starts within 5 seconds. To start the handset press and hold the Call key ; the question "Switch on?" will be displayed. Press "Yes" within 10 seconds.

If a call is connected when the handset is placed in the charger the handset will be charged and fully operational at the same time.

Note: Charging below 0°C will harm the battery and shorten the lifetime.

Note: The handset can be charged in the wall-mounted Charging Rack without removing the pull-cord catch.

IMPORTANT: Charging of 9d24 MkII ATEX/IECEx-Messenger and 9d24 MkII ATEX/IECEx-Protector is NOT permitted in hazardous area.

Note: When charging an ATEX/IECEx-version the Desktop Charger must be marked with DC2 and the Charging Rack must be marked with CR2.

Charging parameters: $U_m = 5,25 \text{ V}$, $I_m = 1,25 \text{ A}$

11.1.1 Charging Spare Batteries

Spare batteries can be charged in the wall-mounted Charging Rack equipped with the battery pack adapter.

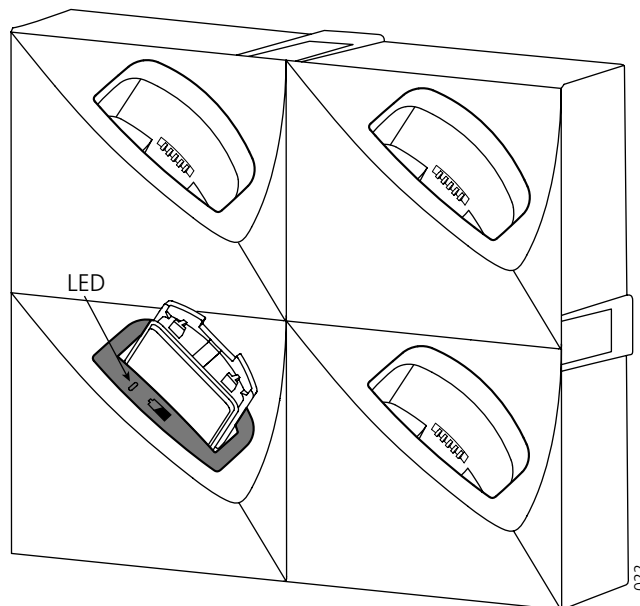

Figure 17. Inserting a battery in the Charging Rack equipped with an adapter.

Place the battery in the charging slot. The LED on the adapter starts flashing green, one flash per two seconds, see [figure 17](#) on page 58. When the battery is fully charged, the LED will show a steady green light.

If the LED does not start to flash when the battery is placed in the charging slot, the battery is not in contact with the adapter. If the LED flashes rapidly, two flashes per second, there is an error. Remove the battery and put it into the charging slot again.

Note: It is not possible to charge spare batteries in the Desktop Charger.

11.2 Replace the Standard Battery

The battery is fastened by a screw and two hooks. To remove the battery use the Battery Pack Opener.

- 1 Switch the handset off. See [9.3.5 Switch the Handset Off](#) on page 43.
- 2 Place the narrow end of the Opener in the screw and turn it to horizontal position.
- 3 Flip the Opener over and hook it onto the screw.
- 4 Pull the screw and battery out

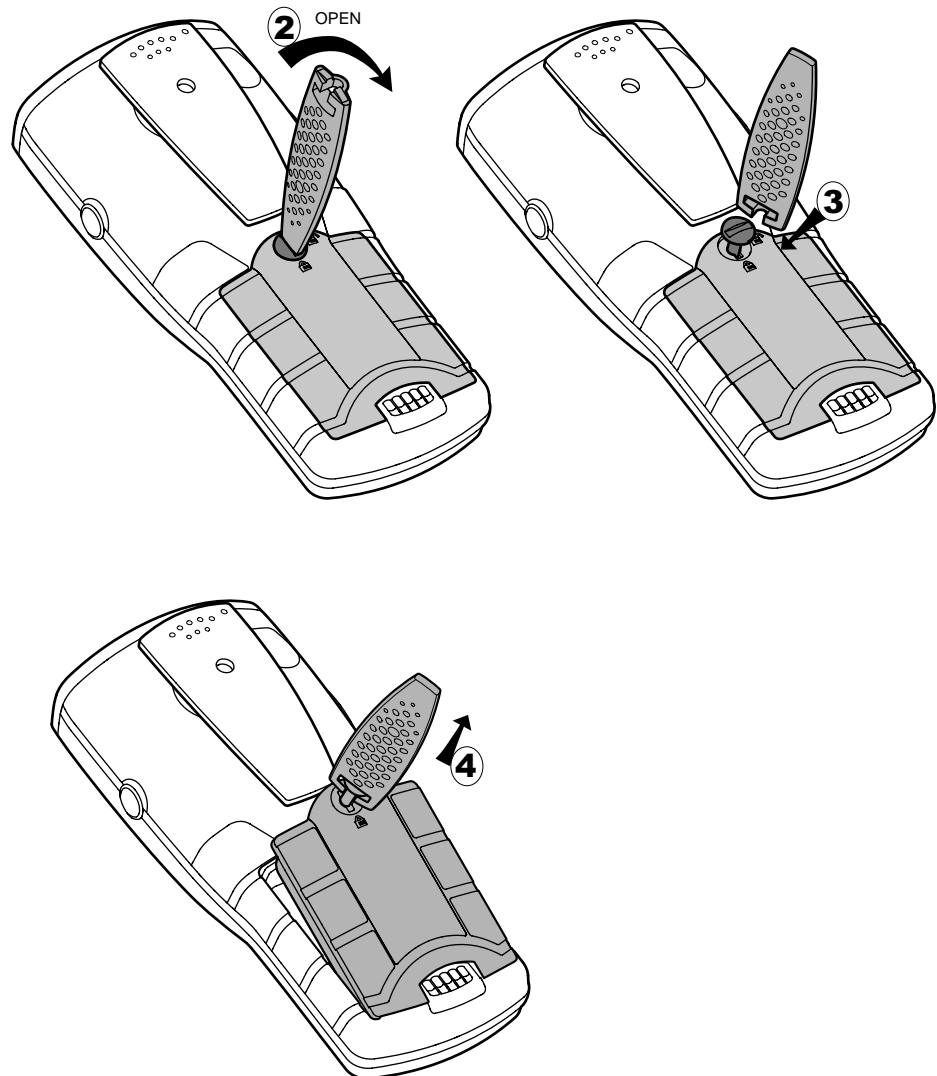

Figure 18. Use the Battery Pack Opener to remove the battery.

Note: Avoid using a screwdriver as it may damage the screw.

- 5 Exchange the battery. Make sure the screw is in horizontal position.

- 6 Press the battery in place.
- 7 Use the narrow end of the Opener to push down the screw and turn it to vertical position.

11.3 Replace the ATEX/IECEX Battery

In combination with ATEX/IECEX-version, use approved battery types only. The battery must be marked with ATEX on the label.

IMPORTANT: Battery replacement is NOT permitted in hazardous area.

The battery is fastened by a screw that requires a special tool, Battery pack opener for ATEX. To remove the battery, use the opener and turn the screw to horizontal position. Remove the battery by pulling the screw. When fastening the battery again the screw has to be in horizontal position. To fasten the battery use the opener and turn the screw to a vertical position.

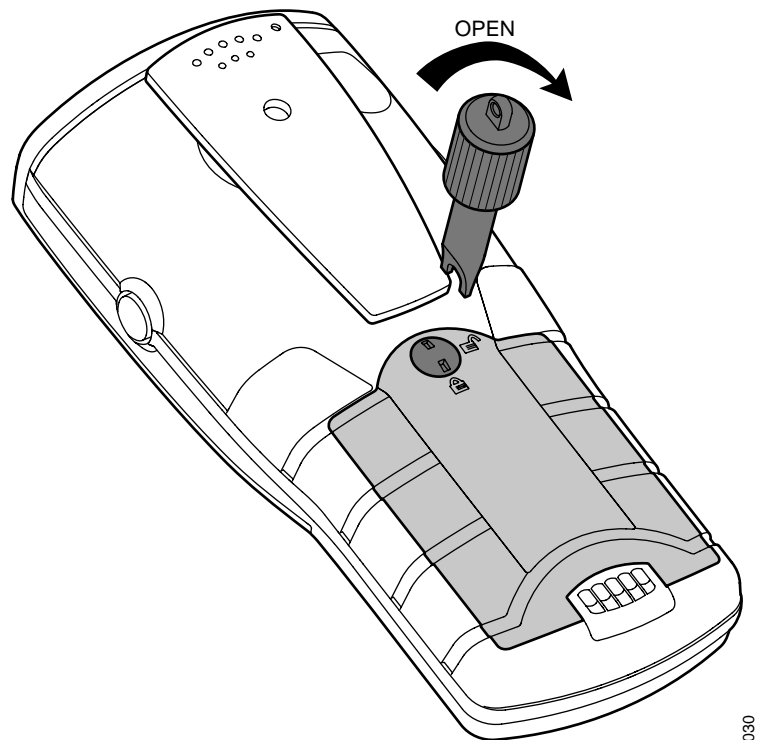

Figure 19. Turn the screw to horizontal position with the opener.

11.4 Change the SIM Card

Remove the battery as described above. Slide the SIM card out of position. Insert the new SIM card and slide it into position.

11.5 Change the Clip

A hinge-type belt clip is mounted on the 9d24 MkII Cordless Handset at delivery. The clip can be replaced with a covering plate that is in the delivery or a swivel-type belt clip that can be ordered separately.

Tools required:

- Pozidriv Point size 1

11.6 Attach Pull-cord Protection Plug

Disable the pull-cord alarm, see [9.5.7 Deactivate/Activate Pull-cord alarm](#) on page 46.
Remove the pull-cord and replace it with the Protection plug.

12 Trouble Shooting

Problem	Solution
The handset does not start	Check that the correct battery type is used. "Only to be used in RAID2-XXXXX" should be printed on the label on the battery, see 3.2 Battery on page 6. If the battery is correct make sure it is fully charged.
The handset beeps once a minute (during max 30 minutes) with a low tone followed by a high tone (if enabled, the vibrator also follows the beeps). "No System" appears in the display. (It is possible to adjust the beep volume via the ring signal volume setting.)	The <i>handset is out of coverage</i> : Stop the beep with the mute button and go into range. Note: When re-entering the coverage area it can take a couple of minutes before the handset automatically has registered into the system. or It is a <i>no system warning</i> : Remove and then insert the battery again to make the handset connect to the system automatically. IMPORTANT: For ATEX/IECEx handsets, battery charging or replacement or opening of the battery compartment is NOT permitted in a hazardous area.
Bad voice quality	For best voice quality, avoid positioning near computer, radio or similar.

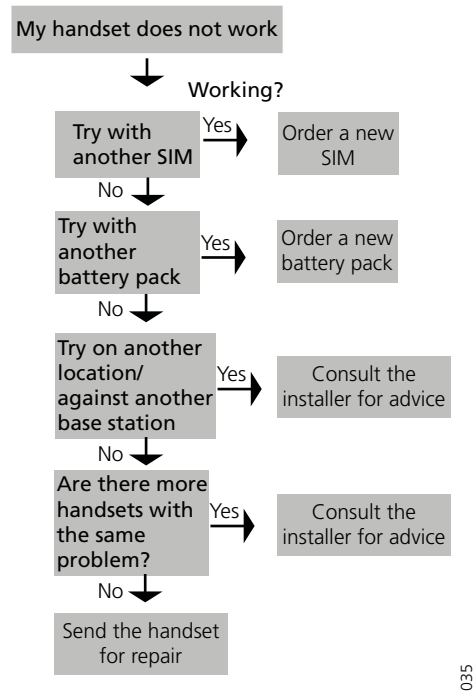

Figure 20. Trouble-shooting the 9d24 MkII handset.

12.1 Error message

Error message	Solution
Check SIM card	Check that a 9d24 or 9d23 SIM card is used and that the SIM card is properly positioned.
SIM failure	The SIM card has corrupt data and needs to be replaced. Contact the system administrator.
Consult manual	
EEPROM failure	Malfunction detected, handset needs repair.
Service needed	
HW failure	The software is not compatible with this handset.
HW not supported	Download supported software.
SW failure	The software is not compatible with this handset.
SW not supported	Download supported software.

Note: Some error codes are only shown in english.

Document History

For details, see change bars in the document.

Version	Date	Description
C		Minor editorial changes. 2.2 Battery New chapter 2.4 New icons 3.14 Call menu New menu 9.1.1 New functions, Alcatel deleted
D	2007-02-07	Chapter 3.5: Decline an incoming call - New chapter. Chapter 4.1: Changes in text. Chapter 7.5: New functions under menu "Phone call". Chapter 11.1: Changes in text. Chapter 11.3: Remove the battery - New chapter. Chapter 11.4: Fasten the battery - New chapter.
E	2008-04-16	Changes in Regulatory texts. Insert of trouble-shooting guide. Minor changes in existing functions or added functions like display contrast, volume up during ringing, mute function during ringing, extended call functions (headset button, charging function, hot-key) IM, PTT, reset warning signal before an alarm, change mode remotely, location request. Call setup function.

Appendix A: 9d24 Mkl Functionality with a 9d23 SIM

The 9d24 Mkl Cordless Handset can be used with a 9d23 SIM card but the functionality will be limited as described below.

9d24 Mkl Functions that are not working

- Man-down alarm does not work.
- Central phonebook from Contacts menu is not available.
- Modes are not available.
- Switch off from modes menu is not possible.
- Services are not available.
- Internal call, External call and Callback will have the same Ring signal setting.
- Soft keys cannot be used.
- Some Hot key shortcuts cannot be used, see [Hot keys](#) for more information.

9d24 Mkl Functions that are working

- Phone calls to and from the handset
- Messages
- SMS from the handset
- Interactive Messaging
- Push-button alarms
- No-movement alarm
- Pull-cord alarm works but has to be activated every time the handset is restarted.

Hot keys

The 9d23 and 9d24 Mkl do not have the same set of Hot key functions. When the Hot keys on a 9d23 SIM are programmed with functions, the following applies:

9d23 Function	9d24 Mkl shortcut
Manual absent on	Absent on/off
Manual absent off	Pull-cord alarm on/off
Switch off	Switch off
Change system	Change system
No-movement alarm on	No-movement alarm on/off
No-movement alarm off	Man-down alarm on/off
Edit alarm data	Edit alarm data
RSSI	RSSI
Demo message 1	Demo message 1
Demo message 2	Demo message 2

It is not possible to program the 9d23 SIM card with the shortcuts Local phonebook and Services.

Note: If a Hot key indicates Man-down alarm when a 9d23 SIM is used, the handset will indicate "Wrong SIM" when the Hot key is pressed.

Index

Numerics

- 9d24 Messenger 2, 16, 20–21, 45
- 9d24 MkII EX_Protector..... 2
- 9d24 MkII EX-Messenger..... 2
- 9d24 Protector 2, 16, 20–22, 24, 28–29, 44–45
- 9d24 Talker..... 2, 28–29, 45

A

- Alarm Module 22, 24, 43
 - software version..... 43
- antenna 3

C

- call information upside down 42
- call list..... 7–8, 11, 32, 34
- case
 - covering plate 54
- case materials..... 3
- clip
 - covering plate 4
 - hinge-type 4, 11, 54
 - swivel-type..... 4, 10, 54

D

- date 8
- display..... 4

E

- EX classified Headset 11

F

- Field Upgrade..... 30, 45

I

- Immediate Alarm Transmission 44
- IPDI 43
- IPEI..... 43

K

- keypad..... 4

M

- message list..... 7–8, 16, 31

O

- owner ID 6

P

- pause in a phone number..... 12, 33, 40
- priority 17
- pull-cord alarm..... 6, 10, 23, 54

S

- show current date 8
- Software version 43
- Special location 44
- system ID 6

T

- tone sender..... 12, 33, 40

W

- write letters..... 10